





### Conventions

**Important**  This manual must be read in full before Installation, Operation and Maintenance of the units supplied

Please ensure that this document is passed to the end user. This manual forms an integral part of the product and should be kept for the working life of the product. Additional copies of this and supporting documents are available by contacting VES or by visiting [www.ves.co.uk](http://www.ves.co.uk) and following the 'Download O & M's' link.

The following symbols used within this document refer to potential dangers, advice for safe operation or important points of reference

**Warning**  Indicates hazards associated with electric current and high voltages

**Caution**  Indicates hazards that require safety advice for personnel or potential unit/property damage

**Important**  Indicates important information

| Contents                          | Page |
|-----------------------------------|------|
| 1 Introduction .....              | 3    |
| 2 Nomenclature .....              | 3    |
| 3 Receipt of Goods/Handling ..... | 4    |
| 4 Installation .....              | 4    |
| 5 Set-up .....                    | 7    |
| 6 Wiring .....                    | 9    |
| 7 Controls .....                  | 14   |
| 8 Maintenance .....               | 15   |

**Introduction 1** The T-Line is a range of direct drive duct mounted extract fans, designed typically for arduous conditions i.e hot air with high grease content. The standard ambient operating temperature of the unit is -20 to +40°C, with in-duct airflow temperature up to 120°C.

For further technical details regarding dimensions and weights, contact VES andover Ltd. on **02380 46 11 50** quoting the sales order (SO) number and the unit type as found on the unit name plate or visit [www.ves.co.uk](http://www.ves.co.uk).

**Important**



An Inverter Speed controller is required for the operation of this fan

**Nomenclature**  
Part Number Coding

**2**

| Point description       | Point Variants  | Details  |
|-------------------------|---|--|
| 1 Product               | TLL   | T-Line 120 Extract Unit  |
| 2 Unit Size             | 250<br>350<br>400<br>450<br>500<br>560<br>630<br>710<br>800 | Unit size determined by impellor size  |
| 3 Number of motor poles | /2<br>/4<br>/6  | 2 Pole<br>4 Pole<br>6 Pole   |
| 4 Motor efficiency      | 1<br>2<br>3   | IE1 (EFF2)<br>IE2 (EFF1)<br>IE3  |
| 5 Phase                 | -3  | Three Phase  |
| 6 Unit configuration    | /PH<br>/PL<br>/WH<br>/WL                                    | Plantroom straight through<br>Plantroom c/w bottom inlet<br>Weatherproof straight through<br>Weatherproof c/w bottom inlet |
| 7 Enclosure Options     | Null<br>/AE   | Standard configuration<br>Acoustic Enclosure   |
| 8 Colour                | Null<br>R7004   | Galvanised plantroom / RAL7004 weatherproof<br>Powder coat finish to any colour  |
| 9 Powder coat type      | Null<br>/IT<br>/BT  | Galvanised plantroom/RAL7004 weatherproof<br>Internally only as colour<br>Both internally and externally coated as colour  |

Typical example

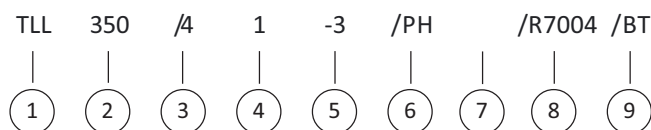

**Receipt of Goods 3** Immediately upon receipt of goods, check for possible damage in transit. Also check to ensure that any ancillary items are included. These will be supplied fitted or taped to the unit (in the case of small items). In the event of any damage having occurred or if any item is found to be missing, it is essential to inform VES Andover Ltd. within **7 working days** of delivery, quoting the sales order (SO) number, and the unit type as found on the unit nameplate. After this period VES Andover Ltd. will be unable to accept any claim for damaged or missing goods.

**Important**  The unit should NOT be lifted by handles, lids, housings, shaft, motor or drive.

When moving the unit, handle with care and in such a manner limiting damage to the casework. Particular care must be taken when moving weatherproof units, any damage to the external powder coat finish may reduce the ability to resist corrosion. Units are to be rigged and lifted using spreaders, taking into account the weight of the unit, lifting gear should be arranged so as not to bear on the casework.

**Installation 4**

**Caution**  Only experienced engineers should undertake this work.

**Important**  An Inverter Speed controller is required for the operation of this fan

Safety for the entire system must be considered when installing the unit and it is the responsibility of the installer to ensure that all of the equipment is installed in compliance with the manufacturer’s recommendations, with due regard to the current **HEALTH AND SAFETY AT WORK ACT** and conforms to all relevant statutory regulations. Precautions should be in place so that in the unlikely event of component failure the risk of personnel injury is reduced. For optimum unit performance, careful consideration must be paid to the location of the unit in relation to the ductwork and associated items; i.e placing the unit directly adjacent to a bend in the ductwork will impede airflow and reduce performance.

**Lifting and Connecting to Duct**

Fig. 1

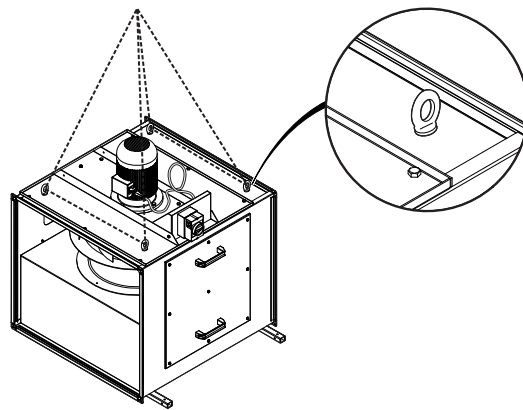

Secure lifting cable through the lifting lugs. Ensure fan plate is securely in place before lifting the unit. It is recommended that the unit is lifted using the supplied lifting lugs.

**Duct Connections**  
(For illustration purposes only)

Fig. 2

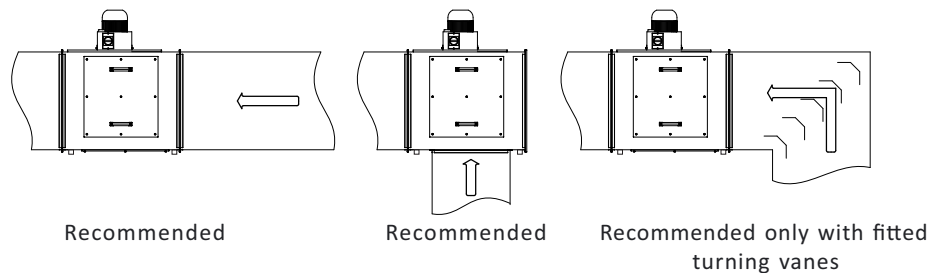

Installation 4 Continued

**Caution**  Units should only be supported using the support feet as provided by VES Andover Ltd. with the unit. Contact VES Andover Ltd. before attempting to support the unit using alternative methods. Only experienced engineers should undertake this work. Take necessary safety precautions when working in elevated positions.

**Caution**  Consideration must be given by the installer to the possibility of unit vibration and steps should be taken to avoid instances where vibration may occur. Flexible connections and anti-vibration mounts should be used where appropriate. Specific mounting kits are available, contact VES for details.

The T-Line unit is designed to be mounted in a range of orientations. The unit can be suspended from the ceiling using drop-rods, or bolted to the plant room floor. It is the installer's responsibility to ensure that there is safe working access provided to the unit for maintenance. The installer must also consider, adequate illumination of the unit, in order for safe maintenance to be carried out.

T-Line Unit Orientation

Fig. 3

All Sizes

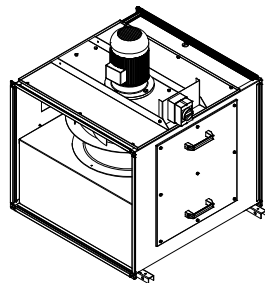

- Motor on top
- Access on both sides
- Feet mounted on bottom

250 - 630 only  
(not available as standard for 710 & 800 - please speak to the VES sales team regarding special motor mounting options)

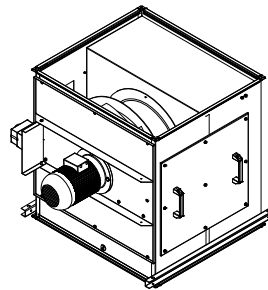

- Motor on side
- Access on both sides
- Feet mounted either side of the access sides

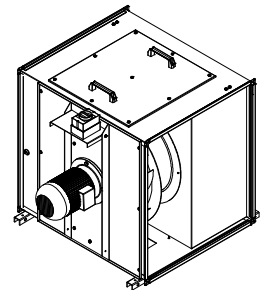



- Motor on side
- Access on top and bottom
- Feet mounted on bottom access side

**Warning**  The electrical supply must be fully isolated before attempting to complete any work on this unit. All electrical connections to any unit must be carried out in accordance with the current edition of the I.E.T Regulations and only competent electricians should be allowed to carry out any electrical work to our units.

Fixing Feet and AV Mounts

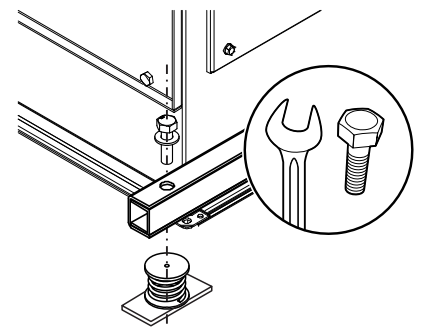
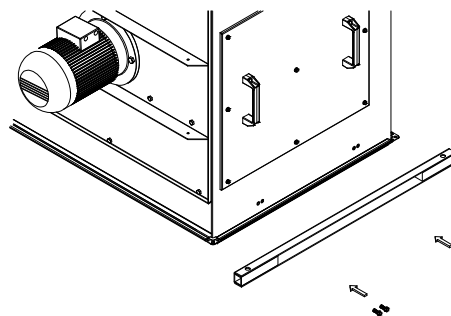
Fig. 4



**Important**  Fix mounting feet to the correct side dependent on the orientation of the unit. Ensure ALL fixings are used. If repositioning feet, ensure all fixings are reinstated and tightened to. When used with anti-vibration (AV) mounts, ensure the correct fixings are used appropriate to the size of the AV and the system is correctly seated and secured. AV mounts are normally used in conjunction with flexible duct connection.

**Installation 4** Continued

Changing the handing of the isolator consists of removing the bracket fixings, re-attaching the bracket to the opposite side.

**Important**



As standard, isolators are hard-wired to the motor. Older units may feature plugged connection.

Handing Isolator  
Plate

Fig. 5

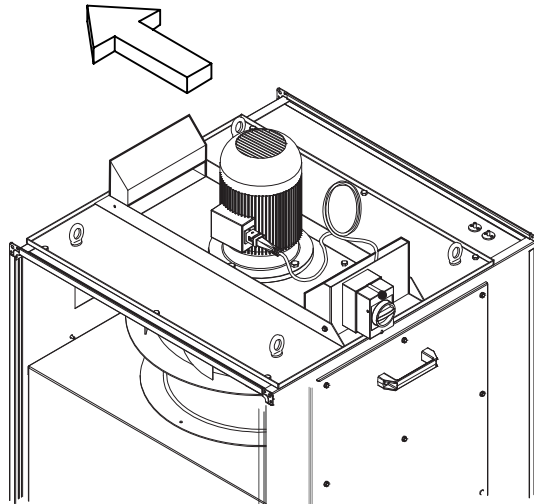

**Warning**



For units with plugs, ensure pins are correctly paired when connecting the plug to the isolator

**Important**



On weatherproof units the motor must be guarded, this is done by rotating the motor guard to the correct orientation. (Meshed edges facing the ground).

Handing Motor Guard

Fig. 6

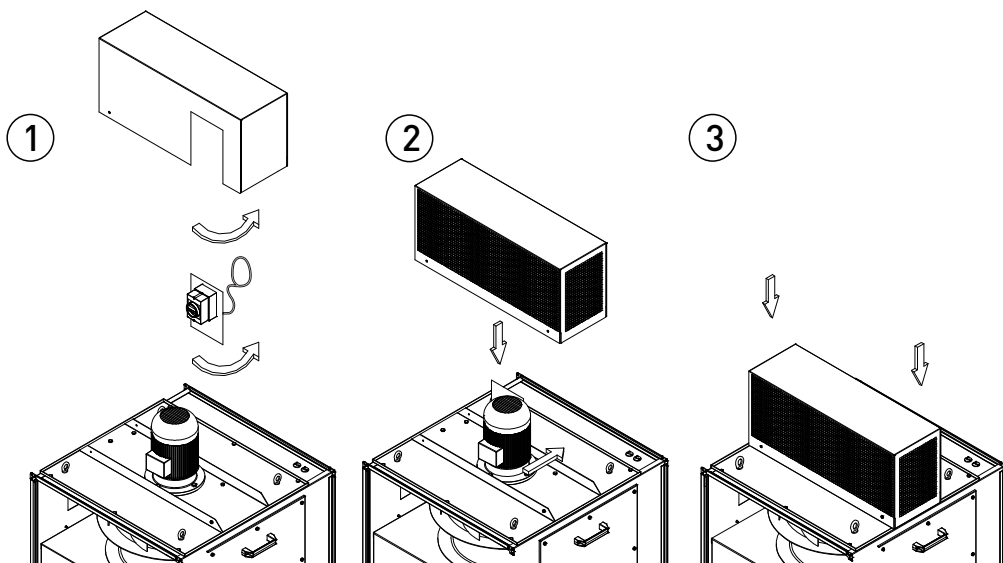

Set-up 5

**Important**



Before starting the unit ensure the following set-up procedures are completed. Work to be carried out by a competent engineer.

Before attempting to carry out any work on our units, all accompanying documentation including warning labels on the unit must be referenced. Should it be necessary to remove any component ensure that these are secured into position once reinstalled. It is critical that after any maintenance work has been conducted that all components removed/replaced are refitted correctly by a competent engineer.

**Warning**



Before attempting to carry out any maintenance work, investigative work, or repair work on our units, the unit **MUST BE COMPLETELY ISOLATED** from its electrical supply. Ensure a minimum of two minutes after electrical disconnection before removing access panels.

**Caution**



When accessing the unit always use the handles to ensure the access panels are handled/opened in a controlled manner so as to avoid damage to the unit or injury to personnel. This is particularly important with bottom access units.

**Important**



The impeller should rotate freely, this position is factory set. In the unlikely event of movement during transit realign the impellor with the inlet eye.

**Impeller/Inlet Eye Alignment**

Remove the access panels and loosen the bolts holding the inlet eye in place. Align the inlet eye and impeller ensuring the inlet eye is central to the impellor and make sure gap 'A' is constant. Hand tighten the bolts and rotate the impellor to ensure the it runs smoothly, secure into position b y tightening the retaining bolts.

Fig. 7

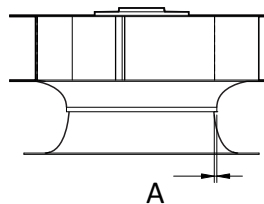

**Caution**



Ensure that the clearance gap 'A' between fan and inlet eye is constant. Misalignment may cause undue wear on the impeller and inlet eye.

**Impeller rotation**

Fig. 8

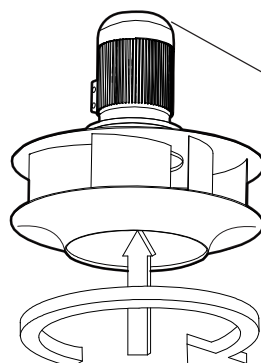

Always make sure the fan is rotating in the correct direction (anti-clockwise when viewed from the motor). Direction of airflow is indicated on the unit.

Note: Motor rotation can be seen on the motor cooling fan on the end of the motor. WP units may require the temporary removal of the motor cover.

Set-up 5 Continued

Differential pressure tapping point

Fig. 9

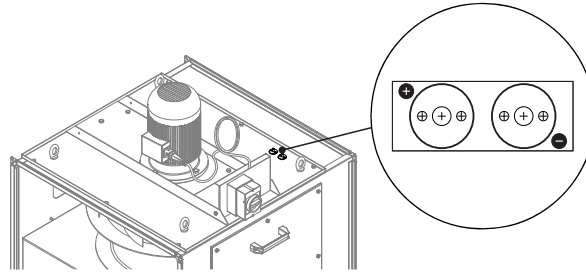

This differential pressure compares the static pressure in front of the fan inlet ring with the static pressure in the inlet ring of the narrowest point. The differential pressure between the static pressures is related to the air volume via the energy conservation rate as per the graph below. Simply read across from the pressure measurement to the appropriate fan curve and down to calculate the resultant air volume.

Example: Measured differential pressure: 1400Pa - Unit: TLL400  
Reading from graph: 1.6 = Air Volume: 1.6 m³/s

Fig. 10

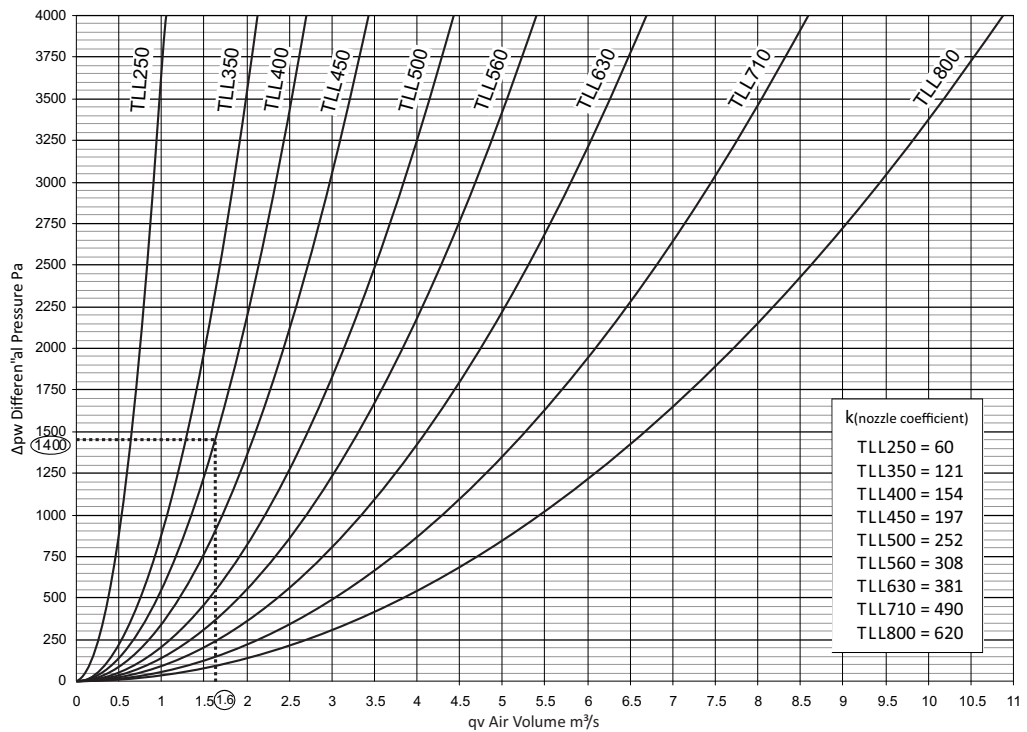

This measurement can also be expressed in the following calculation:

$$q_v = (k \sqrt{\Delta p_w}) / 3600$$

$q_v$  is the air volume in m³/s  
 $k$  is the fan nozzle coefficient  
 $\Delta p_w$  is the measured differential pressure in Pa

Example:

Measured differential pressure: 1400Pa  
Unit: TLL400

$$q_v = (154 \sqrt{1400}) / 3600$$

$$q_v = (154 \times 37.417) / 3600$$

$$q_v = 5762 / 3600$$

$$q_v = \text{air volume} = 1.6 \text{ m}^3/\text{s}$$

Alternatively, to calculate a differential pressure reading from a volume:

$$\Delta p_w = ((q_v \times 3600) / k)^2$$

Example:

Required air volume ( $q_v$ ) = 1.6 m³/s  
 $\Delta p_w = ((1.6 \times 3600) / 154)^2$   
 $\Delta p_w = (37.4)^2$   
 $\Delta p_w = 1399 \text{ Pa}$



Wiring 6

**Warning** 

The electrical supply must be fully isolated before attempting to complete any work on this unit. All electrical connections to any unit must be carried out in accordance with the current edition of the **I.E.T Regulations** and only competent electricians should be allowed to carry out any electrical work to our units.

**Important** 

Motor and electrical details must be checked prior to connection to electricity supply. All motor information can be found on the unit data sheet supplied attached to the unit. It is the customer's responsibility to supply earth fault protection through the building installation device and a dedicated, isolated power supply with overload protection, to account for motor start-up currents. For specific fan details see table below.

**Warning** 

Do not connect any unit to an electrical supply voltage outside of the specification

**Important** 

An Inverter Speed controller is required for the operation of this fan

VES supply, a fitted pre-wired isolator, mains cables which should be suitably sized, refer to table, and terminated as shown on the appropriate wiring diagram, refer to pages 10-14. Ensure that suitable strain relief is fitted to the mains supply as appropriate.

**Standard  
3 Phase Motor  
Electrical Details**

Fig. **11**

| Model       | 3 Phase Motor Details<br>Motor Description | Motor Plate Details |                   |         | Available Options          |                            |
|-------------|--|---------------------|-------------------|---------|----------------------------|----------------------------|
|             |  | Motor Size (kW)     | Motor Speed (rpm) | FLC (A) | Frequency Inverter 1ph-3ph | Frequency Inverter 3ph-3ph |
| TLL250/22-3 | IE2 0.37 kW 2 Pole 3 Phase                 | 0.37                | 2820              | 0.91    | ✓                          | ✓                          |
| TLL250/42-3 | IE2 0.25 kW 4 Pole 3 Phase                 | 0.25                | 1365              | 0.72    | ✓                          | ✓                          |
| TLL350/23-3 | IE3 2.2 kW 2 Pole 3 Phase                  | 2.20                | 2900              | 4.40    |                            | ✓                          |
| TLL350/42-3 | IE2 0.37 kW 4 Pole 3 Phase                 | 0.37                | 1375              | 0.96    | ✓                          | ✓                          |
| TLL400/23-3 | IE3 4.0 kW 2 Pole 3 Phase                  | 4.00                | 2888              | 7.10    | ✓                          | ✓                          |
| TLL400/43-3 | IE3 0.75 kW 4 Pole 3 Phase                 | 0.75                | 1440              | 1.68    | ✓                          | ✓                          |
| TLL450/43-3 | IE3 1.1 kW 4 Pole 3 Phase                  | 1.10                | 1442              | 2.30    | ✓                          | ✓                          |
| TLL500/43-3 | IE3 1.5 kW 4 Pole 3 Phase                  | 1.50                | 1439              | 3.20    | ✓                          | ✓                          |
| TLL560/43-3 | IE3 3.0 kW 4 Pole 3 Phase                  | 3.00                | 1452              | 5.90    | ✓                          | ✓                          |
| TLL630/43-3 | IE3 5.5 kW 4 Pole 3 Phase                  | 5.50                | 1464              | 11.40   |                            | ✓                          |
| TLL630/63-3 | IE3 2.2 kW 6 Pole 3 Phase                  | 2.20                | 967               | 5.20    | ✓                          | ✓                          |
| TLL710/43-3 | IE3 7.5 kW 4 Pole 3 Phase                  | 7.50                | 1464              | 14.70   |                            | ✓                          |
| TLL710/63-3 | IE3 3.0 kW 6 Pole 3 Phase                  | 3.00                | 978               | 7.00    | ✓                          | ✓                          |
| TLL800/43-3 | IE3 18.5 kW 4 Pole 3 Phase                 | 18.5                | 1481              | 34.90   |                            | ✓                          |

Wiring 6 Continued

**Warning** ⚡ For units with plugs, ensure pins are correctly paired when connecting the plug to the isolator

**Important** ! An Inverter Speed controller is required for the operation of this fan

**3 Phase Direct on Line Isolator Wiring Diagram**  
Customer connections 400 V AC - 3 Phase - 50Hz

Fig. 12

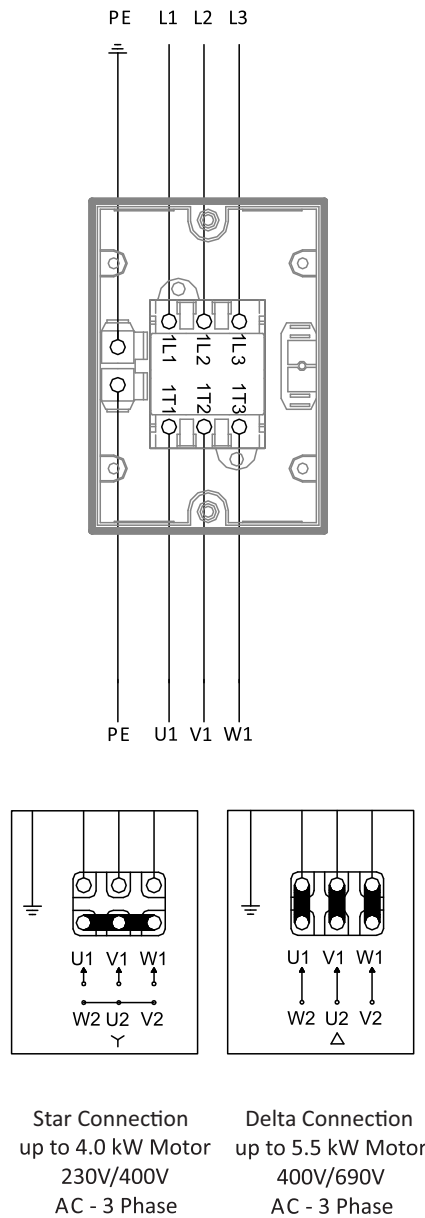

Wiring 6 Continued

**Warning** ⚡ For units with plugs, ensure pins are correctly paired when connecting the plug to the isolator

**Important** ! An Inverter Speed controller is required for the operation of this fan

Fig. 13

**1 Ph - 3 Ph Inverter Isolator Wiring Diagram**

Customer connections  
230 V AC - 1 Phase - 50Hz

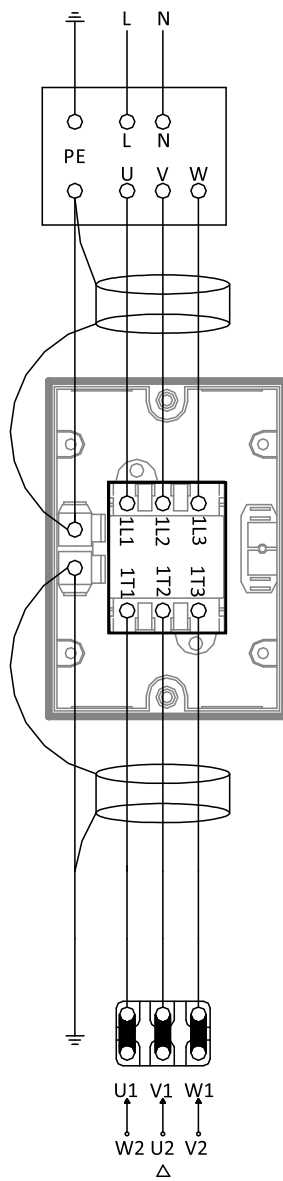

Delta Connection  
up to 2.2 kW Motor  
230V/400V  
AC - 3 Phase

**3 Ph - 3Ph Inverter Isolator Wiring Diagram**

Customer connections  
400 V AC - 3 Phase - 50Hz

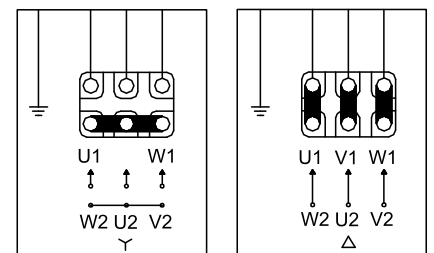
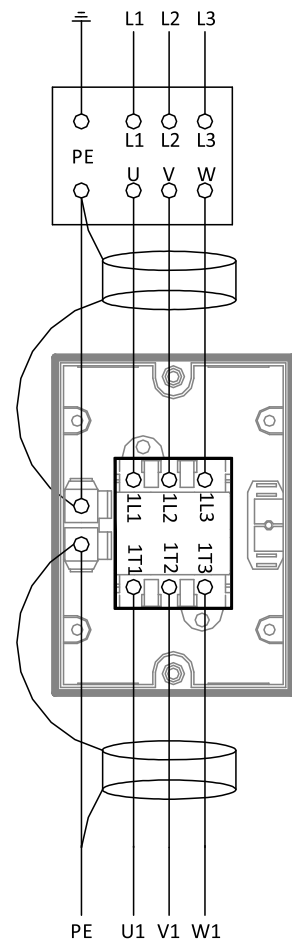

Star Connection  
up to 4.0 kW Motor  
230V/400V  
AC - 3 Phase

Delta Connection  
5.5 kW/7.5 kW Motor  
400V/690V  
AC - 3 Phase

**Wiring 6** Continued

**Warning** ⚡ For units with plugs, ensure pins are correctly paired when connecting the plug to the isolator

**Important** ! An Inverter Speed controller is required for the operation of this fan

Fig. 14

**3 Phase Star/Delta Isolator Wiring Diagram**  
Customer connections 400 V AC - 3 Phase - 50Hz

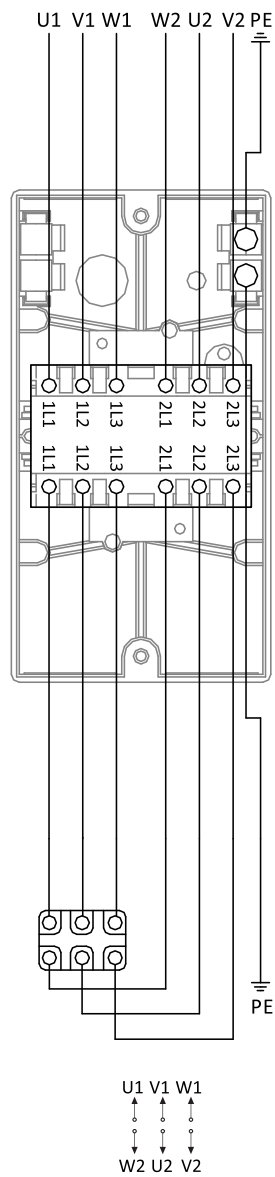

Star/Delta Connection for units with motors 7.5kW larger.

Wiring 6 Continued

**Warning** ⚡ For units with plugs, ensure pins are correctly paired when connecting the plug to the isolator

**Important** ! An Inverter Speed controller is required for the operation of this fan

Fig. 15

**3 Phase Delta Isolator Wiring Diagram**  
Customer connections 400 V AC - 3 Phase - 50Hz

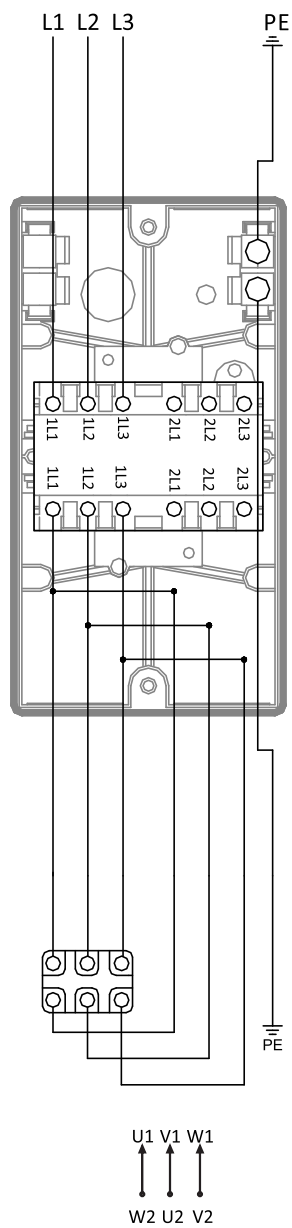

Delta Connection for units with motors 7.5 kW larger.

Controls 7

**Warning**  The electrical supply must be fully isolated before attempting to complete any work on this unit. All electrical connections, to any unit, must be carried out in accordance with the current edition of the **I.E.T Regulations**, and only competent Electricians should be allowed to carry out any electrical work to our units.

**Important**  An Inverter Speed controller is required for the operation of this fan.

VES offer a range of controls suited for the control of selected motors used on the T-Line range. Three phase speed controllers use frequency drivers that offer 0-100% stepless control from a wide range of input signals.

**Important**  Inverters can cause interference to nearby electronic equipment and must be installed correctly to avoid this happening.

Fig. 16

IP21 Inverter



IP54 Inverter

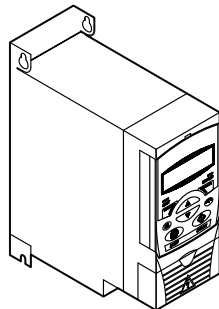
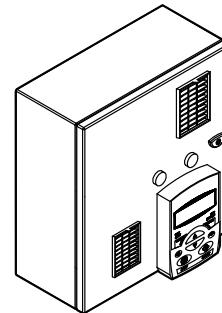

IP21 Inverter Specification

Low cost inverter with IP21 enclosure. Suitable for internal location.

- Sized to match T-Line 3 phase motor.
- Complete with operational keypad.
- IP21/NEMA1 protection for indoor use.
- On/off control at inverter pad with built-in pot for easy adjustment, and BMS control. Remote pot control available (CFSC1).







IP54 Inverter Specification

Inverter with comprehensive range of functions and IP54 enclosure.

- Sized to match T-Line 3 phase motor.
- Complete with operational keypad.
- Optional advanced keypad with built-in time clock.
- IP54 protection for indoor or external use.
- BMS control, remote pot, temperature, constant pressure, humidity and CO2/VOC control.
- Main isolating switch with lockable handle.
- Panel live indicator.
- Damper control.
- Volt free run and trip indication.
- Connections for motor thermal cutout safety interlock.
- Easy customer installation.

**Important**  For information regarding associated components (speed controllers, controls) please refer to the relevant accompanying O&M.

Maintenance 8

- Important**  Before attempting to carry out any work on our units, all accompanying documentation including warning labels on the unit must be referenced. Should it be necessary to remove any component ensure that these are secured into position once reinstalled. It is critical that after any maintenance work has been conducted that all components removed/replaced be refitted correctly by a competent engineer.
- Warning**  Before attempting to carry out any maintenance work, investigative or repair work on our units, the unit **MUST BE COMPLETELY ISOLATED** from its electrical supply. Ensure a minimum of two minutes after electrical disconnection before removing access panels.
- Caution**  Ensure impellor has been allowed to completely stop before attempting to carry out any work on this unit.
- Caution**  When accessing the unit always use the handles to ensure the access panels are handled/opened in a controlled manner so as to avoid damage to the unit or injury to personnel. This is particularly important with bottom access units. Once maintenance has been carried out ensure the motor assembly is secured correctly before restarting the unit.
- Caution**  A failure to keep up with cleaning maintenance could result in the increase of potential risks and fire hazards. Ensure the unit is incorporated into a regular cleaning schedule.
- Caution**  Care must be taken when working on the unit due to potential hot surfaces. Allow the unit to completely cool before commencing any works.

In general, this series of units require little maintenance. Regular inspection for damage and cleaning. In the unlikely event of component failure, spares are available from stock at VES.

**Important**  The impeller should rotate freely and this position is factory set. In the unlikely event of movement during transit or operation realign the impeller with the inlet eye.

Remove the access panels and loosen the bolts holding the inlet eye in place Align the inlet eye and impeller ensuring the inlet eye is central to the impeller and make sure gap 'A' is constant. Hand tighten the bolts and rotate the impeller to ensure the it runs smoothly, secure into position b y tightening the retaining bolts.

Impeller/Inlet Eye Alignment

Fig. 17

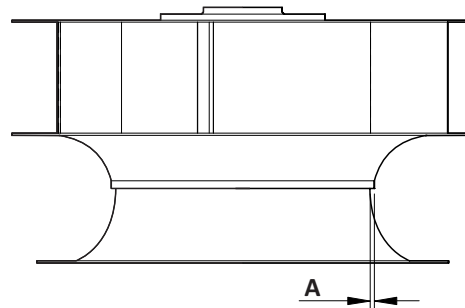

**Caution**  Ensure that the clearance gap "A" between fan and inlet eye is constant. Misalignment may cause undue wear on the impeller and inlet eye.

Maintenance 8 Continued

Always make sure the fan is rotating in the correct direction (anti-clockwise when viewed from the motor). Direction of airflow is indicated on the unit.

Impeller Rotation

Fig. 18

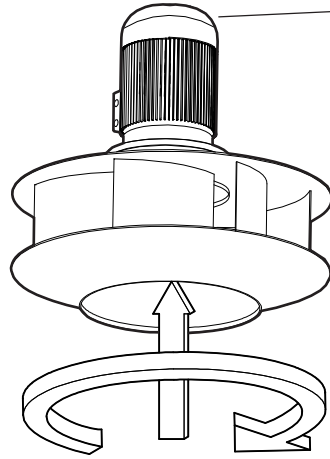

**Note:** Motor rotation can be seen on the motor cooling fan on the end of the motor WP units may require temporary removal of motor cover.

Lifting Fan Assembly

In order to remove the motor plate for maintenance remove the fixings and secure lifting cable to lugs, also ensure the isolator has been disconnected refer to page 6. Ensure fan assembly is tightened before lifting the motor plate off.

Fig. 19

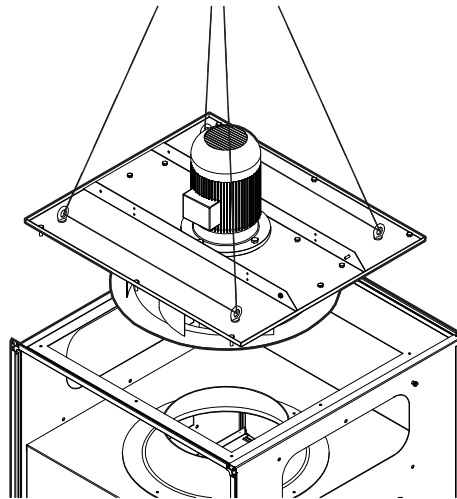

**Caution**



**Lifting Hazard:** Single person lift could cause injury. Use assistance when moving or lifting



**Caution**  If dismantlement is required due to a blockage ensure motor and impeller are reassembled and installed correctly as in the following diagram. For isolator bracket removal refer to page 6.

Fan Assembly

Fig. 20

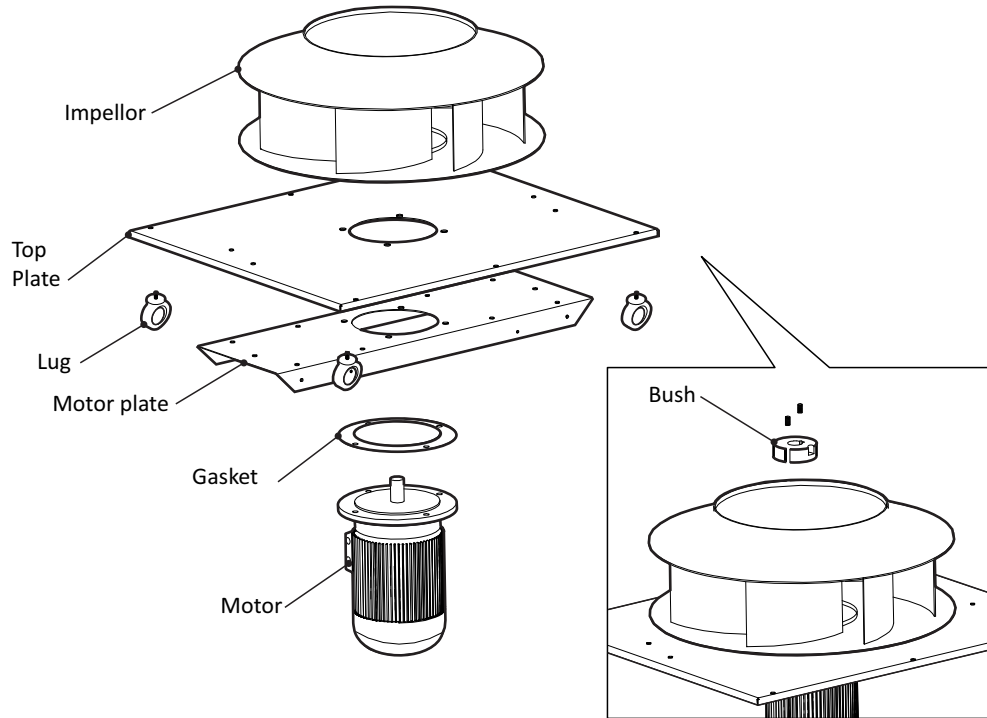

**Caution**  **Lifting Hazard:** Single person lift could cause injury. Use assistance when moving or lifting

**Important**  When re-assembling the fan and motor ensure the bush is secured tightly to the motor shaft with the impeller correctly aligned. Ensure the impeller rotates freely leaving a level gap of 'B' (as shown below) between the impeller and the top plate.

Fig. 21

|                        |      |      |      |      |      |      |      |      |      |
|------------------------|------|------|------|------|------|------|------|------|------|
| Impeller Ø (mm)        | 250  | 350  | 400  | 450  | 500  | 560  | 630  | 710  | 800  |
| Distance B (mm)        | 20   | 20   | 25   | 25   | 20   | 32   | 32   | 28   | 32   |
| Bush Type              | 1210 | 1210 | 1210 | 2012 | 2012 | 2012 | 2517 | 2517 | 2517 |
| Tightening Torque (Nm) | 20   | 20   | 20   | 30   | 30   | 30   | 50   | 50   | 50   |

Fig. 22

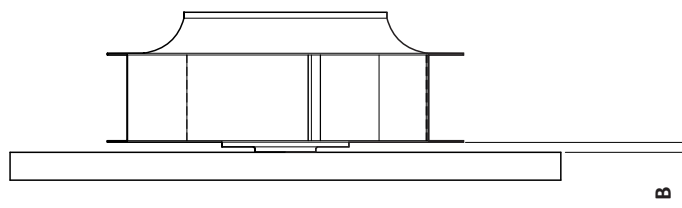

## Maintenance 8 Continued

### Recommended Checks

In order to keep the unit in good order the following maintenance routine is recommended.

### Six Monthly Checks

The fan impeller should be cleaned at least every 6 months, however this may need to be adjusted depending on use of the system. Refer to **TR/19** "*Guide to good practice - cleanliness of ventilation system*" or similar for guidance as to the recommended frequency of maintenance. A failure to clean the fan on a regular basis could result in loss of fan performance, cause it to fall out of balance or cause a potential fire risk.

If a fan is stationary for long periods in a humid atmosphere, it should be switched **ON** for minimum of two hours every month to remove any moisture that may have condensed within the motor.

### Twelve Monthly Checks

T-Line units are supplied in both unpainted and powder coat painted galvanised sheet steel cases. Check all painted items to ensure that they have not deteriorated, particularly where adverse environmental conditions prevail. Re-paint as necessary. Matching paint can be supplied upon request.

### Spares & Repairs

When enquiring about or ordering spares contact VES Spares Department, quoting the sales order (SO) number and unit type found on the unit name plate.

**Tel: 023 8046 1150**

WEEE Directive



At the end of their useful life the packaging and product should be disposed of via a suitable recycling centre. Do not dispose of with normal household waste. Do not burn.

**PLEASE ENSURE THAT THIS DOCUMENT IS PASSED ON TO THE END USER**



# t-line 120

## *Extract Units*

---

### *Operation & Maintenance Manual*

©VES Andover Ltd. 2024  
VES is a trading name of VES Andover Ltd.  
Registered in England No. 02303719.  
Registered Office as above.



Eagle Close, Chandlers Ford Industrial Estate, Chandlers Ford, Eastleigh, Hampshire, SO53 4NF

Tel: +44 (0) 2380 46 11 50

email: [info@ves.co.uk](mailto:info@ves.co.uk)

web: [www.ves.co.uk](http://www.ves.co.uk)



## UK Declaration of Conformity

This declaration is issued under the sole responsibility of the product manufacturer.

**Product:** T-Line 120 Extract Units  
**Type:** TLL  
**Manufacturer:** VES Andover Ltd.  
**Date:** 09<sup>th</sup> December 2022

**The object of the declaration described above is in conformity with the relevant UK Statutory Instruments and their amendments:**

2008 No. 1597                      The Supply of Machinery (Safety) Regulations 2008

**We hereby declare that the product described above, to which this declaration of conformity refers to, is in conformity with the essential requirements of the following standards:**

BS EN ISO 12100:2010              Safety of machinery - General principles for design - Risk assessment and risk reduction  
BS EN ISO 13857:2019              Safety of machinery. Safety distances to prevent hazard zones being reached by upper and lower limbs  
BS EN 60204-1:2018                Safety of machinery — Electrical equipment of machines

**Name:**

A. Reade

J. Attack

**Signature**

**Position of Signatory:**

Director

Associate Director of Engineering



Eagle Close, Chandlers Ford Industrial Estate, Chandlers Ford, Eastleigh, Hampshire, SO53 4NF

Tel: +44 (0) 2380 46 11 50

email: [info@ves.co.uk](mailto:info@ves.co.uk)

web: [www.ves.co.uk](http://www.ves.co.uk)