

AirDoor™

Active Comfort Solutions

Operation & Maintenance Manual

*in partnership
with*



wirthresearch



AirDoor™ is part of the VES Group

Eagle Close, Chandlers Ford Industrial Estate, Chandlers Ford, Eastleigh, Hampshire, SO53 4NF

Tel : +44 (0) 2380 46 11 50

email : operations@airdoor.co.uk

web : www.airdoor.co.uk

VES Ref. ID. VES-DSG-0008

May 2026

Issue: 07

Original Instructions

Conventions

Important  **This manual must be read completely before installation, operation, and maintenance of the supplied equipment.**

Please ensure this document is handed over to the end user. This manual is an integral part of the product and should be kept for the entire service life of the product. Additional copies of this and supporting documents are available by contacting **AirDoor** or visiting www.airdoor.co.uk and following the link 'Download O & M's'.

The following symbols in this document indicate potential hazards, advice for safe operation, or important reference points.

Warning  Indicates hazards associated with electrical current and high voltages.

Caution  Indicates hazards requiring safety instructions for personnel or possible damage to the equipment/property.

Important  Indicates important information.

Contents		Page
1	Introduction	2
2	Nomenclature	3
3	Receipt of Goods & Handling	4
4	Installation	4
5	Standard Wiring & Fan Installation	9
6	Operating Setup	11
7	Maintenance	19

Introduction 1 The **AirDoor™** is a product that uses an active, targeted airflow to improve room comfort while increasing the building's energy efficiency. Positioned directly in the entrance area of retail spaces, it creates an air curtain to reduce weather-related infiltration such as wind (temperature and humidity disturbances) and wind-driven rain (slippery floors).

The **AirDoor™** is suitable for indoor use only.

As standard, each unit is delivered pre-assembled with a control cabinet as specified at the time of order. The standard operating temperature of these units is -5 to +35 °C.

Further technical details on dimensions and weights are available from **AirDoor** at **(+44) 2380 461150** quoting the sales order number (SO number) and the unit type on the unit's rating plate, or alternatively at www.airdoor.co.uk.

Nomenclature 2

Part Number Coding

Point	Description	Point Variants	Details (as appropriate)
1	Product	Air	AirDoor product Group
2	Product	D	AirDoor products
3	Height	/0000 - 3000	Height in mm
4	Width	/0000 - 3000	Width in mm
5	Voltage	/230 /400 /110	Power supply voltage
6	Electrical Phase	/1 /3	1Ph 3Ph
7	Main Filter	Null /G3	No filter G3 (Course 85%)
8	Control Type	/S100 /T100	Siemens (Network/Variant) Trend (Network/Variant)
9	Inlet	null /GL	No louvre (Mk2) Inlet louvre (Mk3)
10	Variation	/01	Sequential
11	Colour	/R7016	Powdercoated finish, RAL Colour Code

Typical Example

AirL/1900/1400/230/1/G3/S100/GL/R7016

Air D /1900 /1400 /230 /1 /G3 /S100 /GL /R7016

① ② ③ ④ ⑤ ⑥ ⑦ ⑧ ⑨ ⑩ ⑪

Receipt of Goods & Handling 3

Immediately upon receipt of goods, check for possible damage in transit, paying particular attention to fan impellers and unit casing. Prior to installation check to ensure alignment and smooth running of the impellers after transit. Also check to ensure that any ancillary items are included. These will normally be supplied fitted or, in the case of small items, taped to the unit. In the event of damage having occurred or if any item is found to be missing, it is essential to inform **AirDoor** within 7 days of delivery quoting the sales order number and unit reference type, as found on the unit identification label. After this period, **AirDoor** would be unable to accept any claims for damage or missing goods.

Installation 4

Important  **Do NOT attempt to install the unit before you have completely read the installation instructions.**

The entire system must be considered for safety purposes and it is the responsibility of the installer to ensure that all of the equipment is installed in compliance with the manufacturer's recommendations, with due regard to the current **Health And Safety At Work Act** and conforms to all relevant statutory regulations.

Where a unit is installed so that a failure of components could result in injury to personnel, precautions should be taken to prevent such an injury. If the unit is installed where there is a reasonable possibility of persons or objects coming into contact with the impeller whilst operational, a guard must be fitted or steps taken to prevent this occurrence. It is the installers responsibility to ensure that access panels are not obstructed in any way and safe working access for maintenance must be provided in accordance with **Health and Safety** and **Building Regulations**. For confirmation of required access please see the appropriate unit outline drawing. Consideration must also be given by the installer for adequate illumination of the unit's location in order for safe maintenance. Further consideration should be given to the unit's position and secured into place in an appropriate and safe way.

Caution  Handle with care. Failure to fully support the unit during lifting may result in damage to the unit

Caution  On some heavy units two people lifting might be necessary.

Important  Auto Doors, Pocket Screen and Door Sensors work may require review by a specialist to ensure legal compliance.

Caution  Full consideration must be given to the acoustics of the unit and the surrounding environment. For unit details, refer to page 8. Seek expert consultation for site-specific requirements.

Installation 4 Continued

The AirDoor™ is designed to be mounted on both sides on 3 M16 threaded rods securely anchored in the floor (6 in total). It is supplied as free-standing, with suitable structural floor mounting to be carried out by the installer. The base plates have 5 holes for various mounting options. Where possible, use all 5, as illustrated below.

Base Plate
Showing fixing holes

Fig. 1

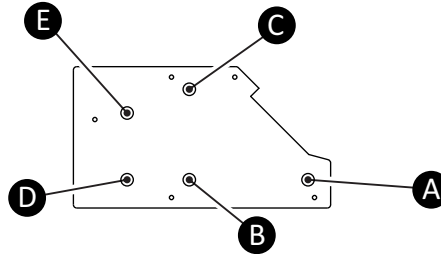

Details of the possible options for installing the AirDoor™, clamped directly to the floor, or for uneven floors where the AirDoor™ is suspended on the installed threaded rods, can be found below. A required structural assessment and/or suitability assessment must be carried out before installation.

We recommend, when using a mounting configuration that does not use point A, screwing the leg with the M8 fixings present in the base through the base plate. The SDDI dimension should be between 200 and 400 mm (as shown in Figure 2).

1. A B C – Standard and preferred option for use on solid floor or when neither of the other options are available

Base Plate Fixing
Solid Floor Area or
Large Floor Matwell
Fig. 2

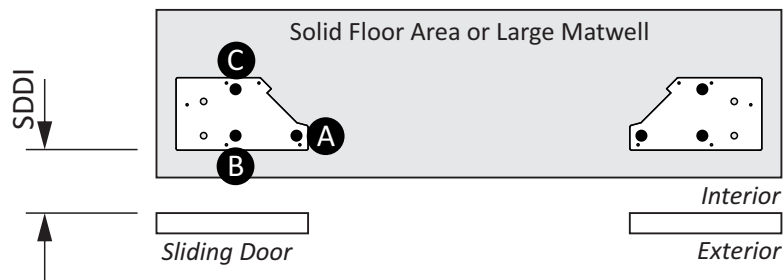

2. B C D – Option to be used on a narrow matwell

Base Plate Fixing
Narrow Floor Matwell
Fig. 3

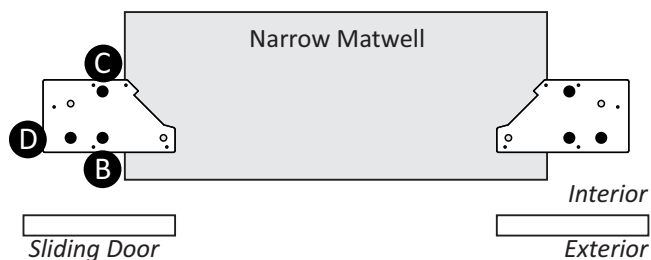

3. B D E – Option to be used on a mid width matwell

Base Plate Fixing
Mid Width Matwell
Fig. 4

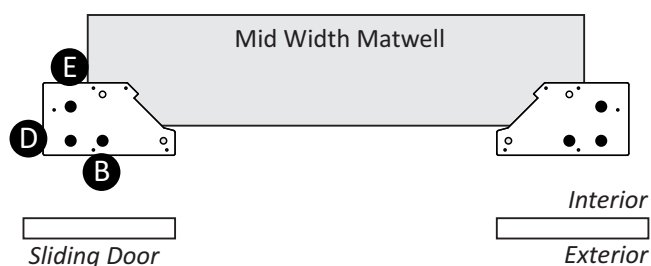

Installation 4 Continued

Uneven Floor
Fixing Details

Please see below how the **AirDoor™** should be fixed on an uneven floor. If this installation is used, the **AirDoor™** must be sized to accommodate the floor offset:

M16 nuts and washers should be placed between the floor and base plate to align the base plates as shown in the diagram.

Please note that the threaded rods should protrude 40 mm above the top of the base plate to ensure the base plate can be secured, but not touch the lowest fan in the leg.

Base Plate Fixing
Uneven Floor
Fixing Details
Fig. 5

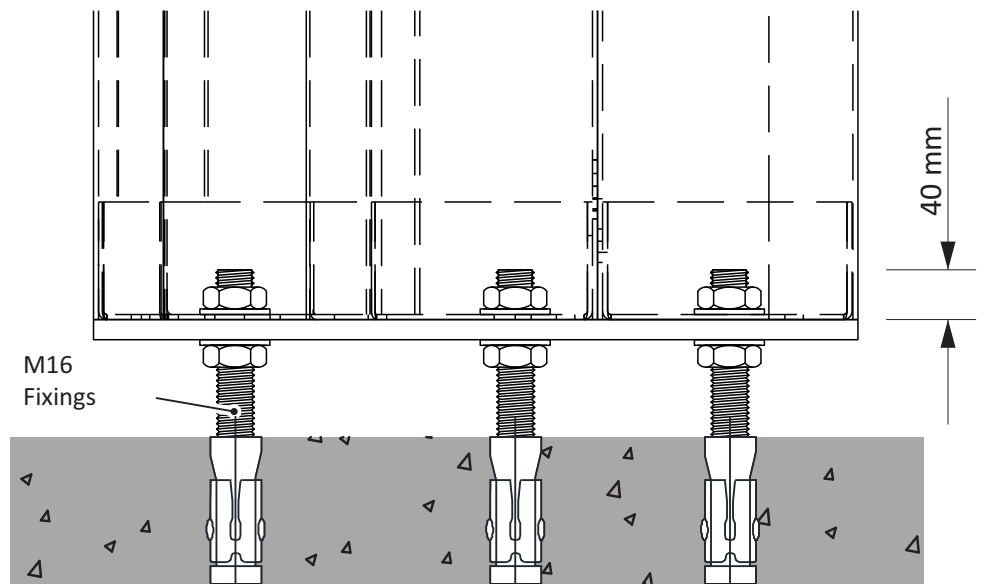

Differential Pressure
Sensors Installation

The **AirDoor™** requires four small pressure sensors to determine the relative pressure inside and outside the building. The two available sensor types are shown below.

Pressure Sensor Detail d
Sensor Ball
Fig. 6

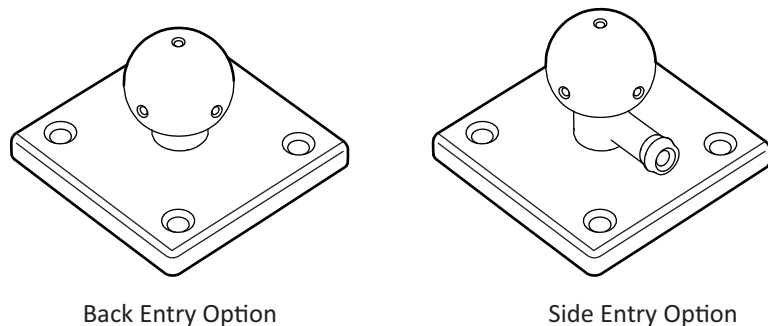

Back Entry Option

Side Entry Option

Installation 4 Continued

Differential Pressure Sensor Installations

One pair of sensors should be connected to a differential pressure sensor and mounted on each side of the door opening in the following configuration.

Pressure Sensor Detail
Differential Pressure Sensor Setup
Fig. 7

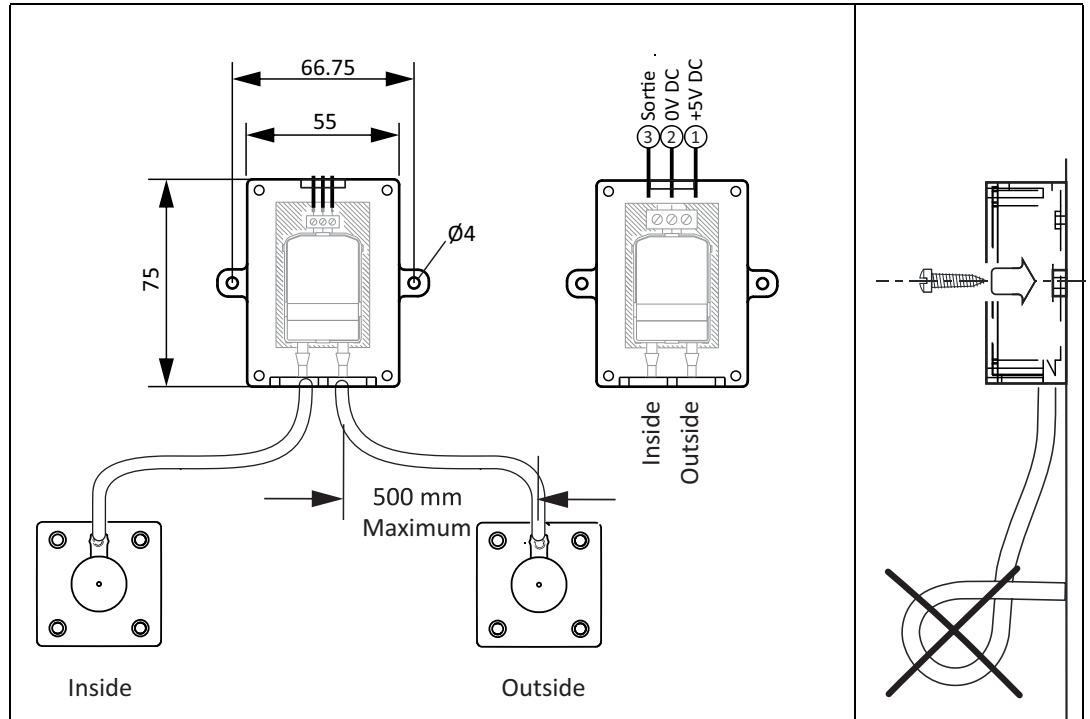

Important



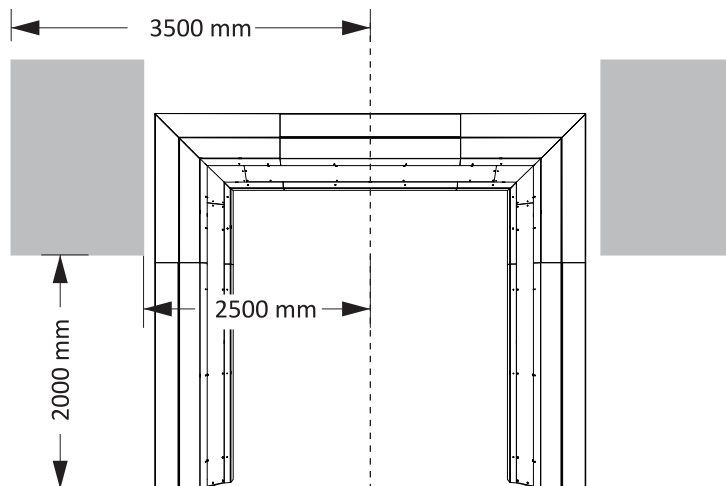

Maximum 500 mm hose between pressure sensor and pressure sensor point. The hose must not be kinked or routed around tight corners. The external pressure sensor should **not** be shielded directly from wind. Internal sensors should not be influenced by other devices such as ceiling heaters, etc. All sensors must be mounted out of reach of customers. One pressure sensor must be attached inside and one sensor outside on the building surfaces, both connected to one differential pressure sensor. The positions of the pressure sensors should be between 2500 and 3500 mm from the door centre line and at least 2000 mm above the floor (shown below)..

Pressure Sensor Detail
Ideal zones for positioning pressure sensors
Fig. 8



Standard Wiring & Fan Installation 5

Warning  The electrical supply **MUST BE FULLY ISOLATED** before attempting to affect any work on this unit. All electrical connections to any unit must be carried out in accordance with the current edition of the I.E. T. Regulations, only competent Electricians should be allowed to affect any electrical work to our units.

Important  It is recommended that the cable entry point should be at the side of the unit as shown below in figure **10**. It is the responsibility of the installer to ensure that a suitable cable gland (giving adequate protection and strain relief) is fitted, and in doing so also ensure that no internal components are damaged during this installation. Make certain any swarf produced is removed before use. It is the customers responsibility to supply earth protection through the building installation device and a dedicated, isolated power supply with overload protection, to account for unit full load current.

Warning  Do not connect any unit to an electrical supply voltage outside of the specification.

Caution  **AirDoor™** Units are designed to run with a maximum fan input voltage of 6.5 Volts. Running fan arrays at higher speeds may generate unwanted noise. Please contact **AirDoor** for guidance should this be required.

Typical unit acoustics **Fig. 9**

Fan Input Voltage	Sound power level, dB re 1 pW, @ octave band centre frequency (Hz)								Overall sound power level <i>L_{WA}</i>	Overall sound pressure level	
	63	125	250	500	1k	2k	4k	8k		<i>L_{pA}</i> @1m	<i>L_{pA}</i> @3m
65%	75	78	85	86	81	82	77	69	88	71	65
60%	76	76	86	84	79	80	75	66	86	69	63
55%	69	73	86	78	76	77	72	63	83	66	60
50%	66	71	84	75	74	75	69	60	81	64	58
45%	63	69	79	72	71	72	65	56	78	61	55
40%	60	67	74	69	68	69	61	51	74	57	51
35%	57	65	70	67	65	64	56	46	70	53	47
30%	53	64	67	62	61	59	50	39	66	49	43

*Units are independently tested at ISVR in accordance with BS EN ISO 3744:2010
Data will vary depending on unit size and location. Data representative for (2x5)x6 fan array unit.*

Standard Wiring & Fan Installation

5 Continued

Recommended Cable Entry Points

Fig. 10

Recommended Cable Entry Points (including HMI)

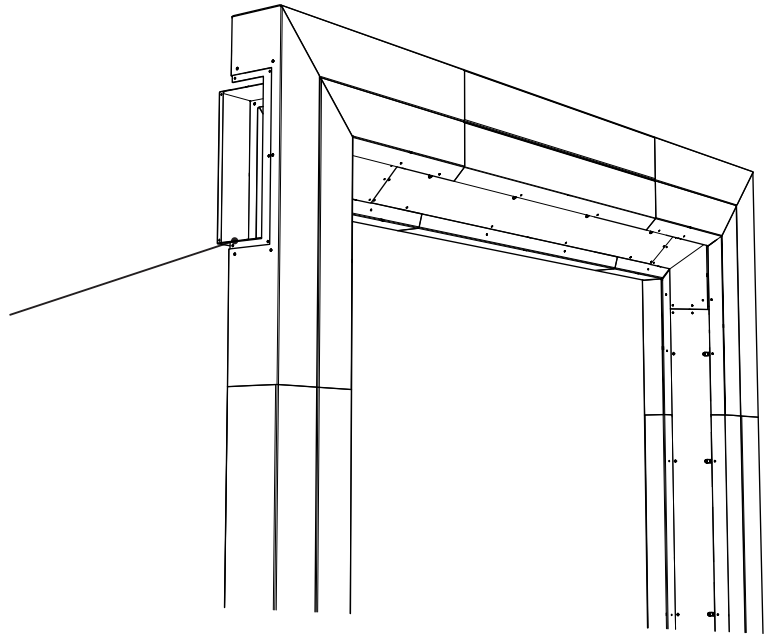

AirDoor™ units are supplied with controls as standard. They are supplied as a panel-mounted control panel within the unit. All units have an RJ45 socket at the cable entry point to allow connection of the operating interface (HMI). This enables the setup and commissioning of the unit via a portable HMI, which can remain connected or be removed as required.

Rj45 Socket / HMI Connection Point

Fig. 11

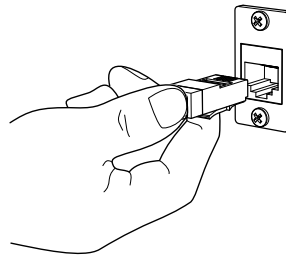

Important

For all units with built-in controls, please refer to the enclosed wiring diagram for full details or contact the AirDoor customer department at **(+44) 2380 461150** quoting the sales order number (SO number) and the unit type on the rating plate.

Caution

The following setup should only be performed by a competent commissioning engineer. Incorrect adjustment will affect the accuracy and performance of the system.

Controls Interface

The AirDoor™ can be connected to online systems that have a virtual HMI. These follow the same steps as below, but require an internet connection for access and do not have the physical HMIs unless specified at the time of order.

Two versions of the HMI are available, a jog dial version and a six-button version. The button operation is described below, but the menu operation is the same for both.

Two operating modes are available. The read-only mode, in which several parameters can be displayed for a quick visual check of the current system status, and the commissioning mode, which allows the user to view and edit all parameters. This includes functions such as adjusting fan speeds, setting up a store switch, etc. Commissioning mode is usually indicated by the presence of 3 buttons in the top right corner; in read-only mode, this area is blank.

Controls Setup 6

HMI Variants Fig 12

PSEL900461
(Six button HMI)

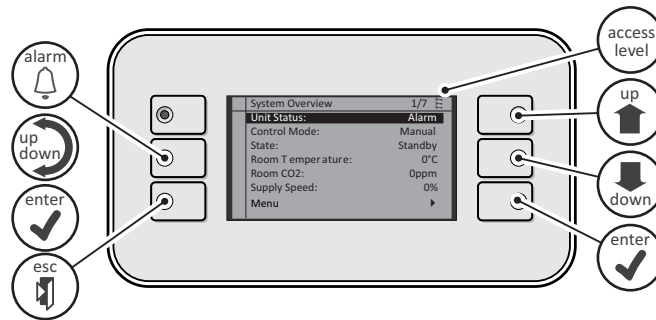

PSEL900463
(Roller button HMI)

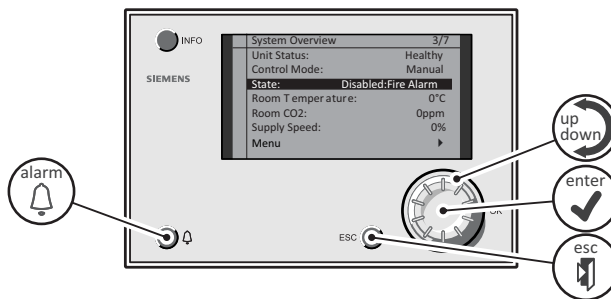

Status Check

1 Plug the HMI into the RJ45 Socket on to unit as shown. Note: when the HMI is first plugged in, it may take up to 45 seconds before the HMI is ready

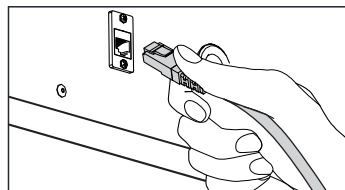

2 Using the **up** and **down** buttons on the HMI, move to the **System Store** field and press **enter**.

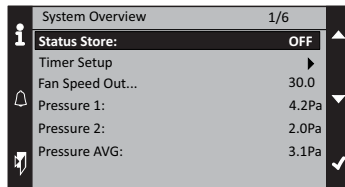

3 Using the **up** and **down** buttons on the HMI, move to the **ON** field and press **enter**.

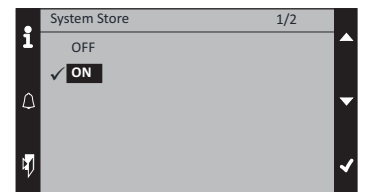

4 The unit should now run as expected.

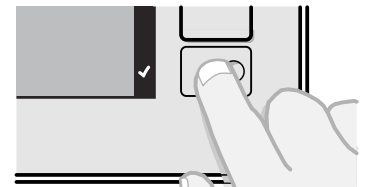

Important



Note that the Pressure 1 and Pressure 2 Fields should be in the range on -25Pa / 25Pa. If this is showing a large number ($\pm 133.8\text{Pa}$ or similar) there might be an issue with one of the pressure sensors. In this case consult the troubleshooting section or contact **AirDoor** on **(+44) 2380 461150**

Controls Setup 6 Setting Timers

1 Plug the HMI into the RJ45 Socket on to unit as shown.

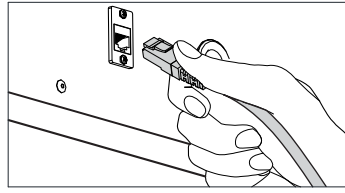

2 Using the **up** and **down** buttons on the HMI, move to the **Timer Setup** field and press **enter**.

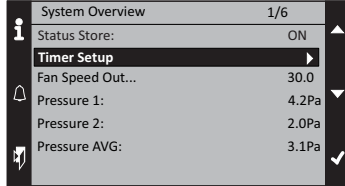

3 Using the **up** and **down** buttons on the HMI, move to the appropriate **day** and press **enter**.

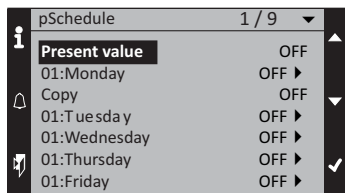

4 Select the **on-time** by scrolling to **Time 1** and press **enter**. The format is in HH:MM. Set **Value 1** to **ON**

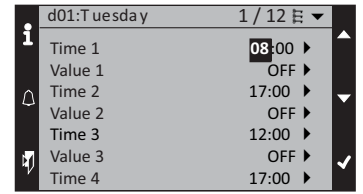

5 Select the **off-time** by scrolling to **Time 2** and press **enter**. The format is in HH:MM. Set **Value 2** to **OFF**



6 All days can be selected in the same way. If there is a day the system is not required then leave all timers off on that day.

Controls Setup 6 Troubleshooting

1 Plug the HMI into the RJ45 Socket on to unit as shown. If the alarm button is illuminated and/or flashing, this indicates a fault within the system. Press **alarm** button to view the details of the fault and act accordingly.

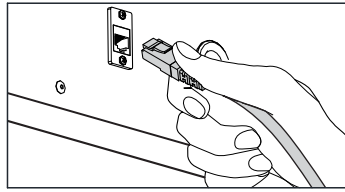

2 To acknowledge the alarm, using the **up** and **down** buttons on the HMI, move to the **Alarms** field and press the **enter** button.

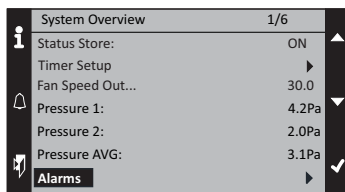
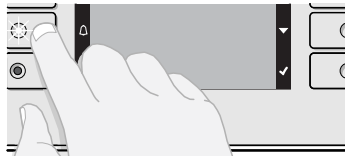

3 Move to **To Acknowledge Enter Password** and press **enter**.

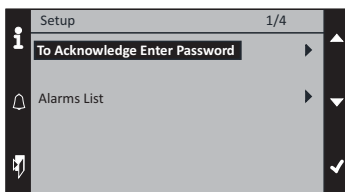

4 Enter password **5973**. This will now return you to the system overview screen.

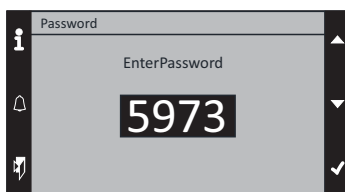

5 Using the **up** and **down** buttons on the HMI, move to the **Alarms List** field and press the **enter** button.

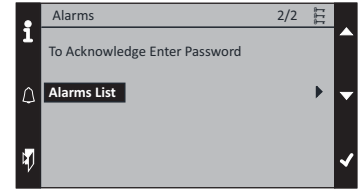

6 Using the **up** and **down** buttons on the HMI, move to the **Acknowledge** field and press **enter**.

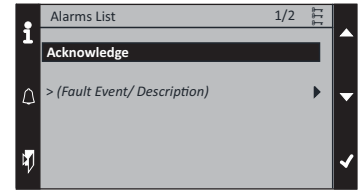

7 Using the **up** and **down** buttons on the HMI, move to the **Execute** field and press **enter**.

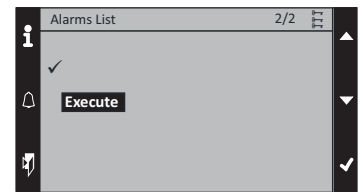

8 Once complete, long press the **enter** button and press **enter** to **log off**.

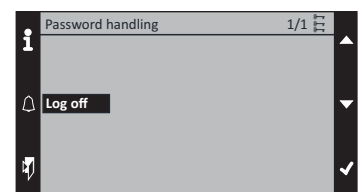

Maintenance 7

Important



Before attempting to carry out work on our units, all accompanying documents, including the warning labels on the unit, must be consulted. If it is necessary to remove a component, ensure that it is securely fastened after reinstallation. It is crucial that after maintenance work, all removed/replaced components are correctly reattached by a competent engineer.

Warning



Before carrying out maintenance, inspection, or repair work on our units, **THE UNIT MUST BE COMPLETELY ISOLATED FROM THE POWER SUPPLY.**

Wait at least two minutes after disconnecting the power supply before removing the access panels. This allows all moving parts to settle. Caution should also be exercised when accessing outdoor units, as wind and weather can cause moving parts to "windmill".

Generally, this series of units requires little maintenance. In the unlikely event of a component failure, spare parts are available from stock at **AirDoor**.

Caution



When accessing the unit, ensure that the access panels are handled carefully to avoid damage to the unit, the environment, or persons. Take all necessary precautions when working at height. Carefully remove the required components and ensure that all components are correctly replaced.

AirDoor™ units feature plug and socket connections to allow easy removal/replacement of key components. Disconnect the connector by hand, pressing the top/bottom locking mechanism to open - no tool is required.

Plug & Socket
Operation
Fig. 13

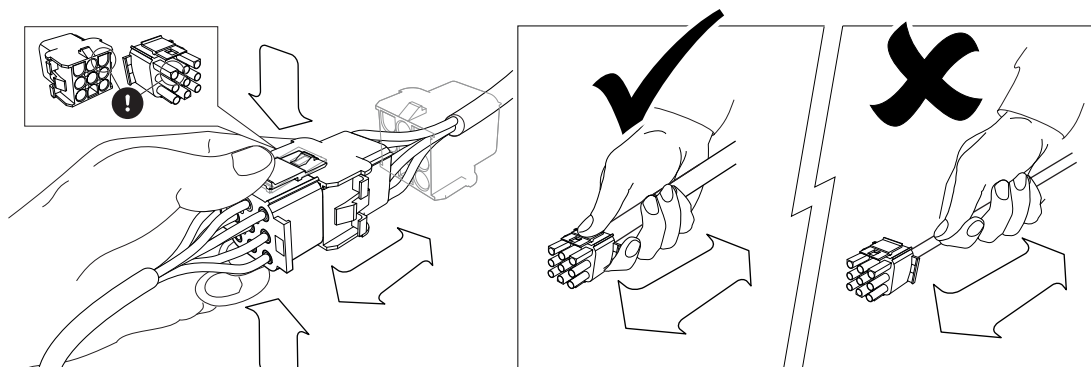

When reconnecting, the assembly has a guide lug to ensure correct alignment. Lock the connection again after mating using the system shown. Note that the plugs are handed and forcing an incorrect connection can damage the plug.

Caution



Carefully pull the plugs apart to disconnect them. Do NOT pull the cable to separate the assembly

Maintenance 7 Continued
Key Components

Fig. 14

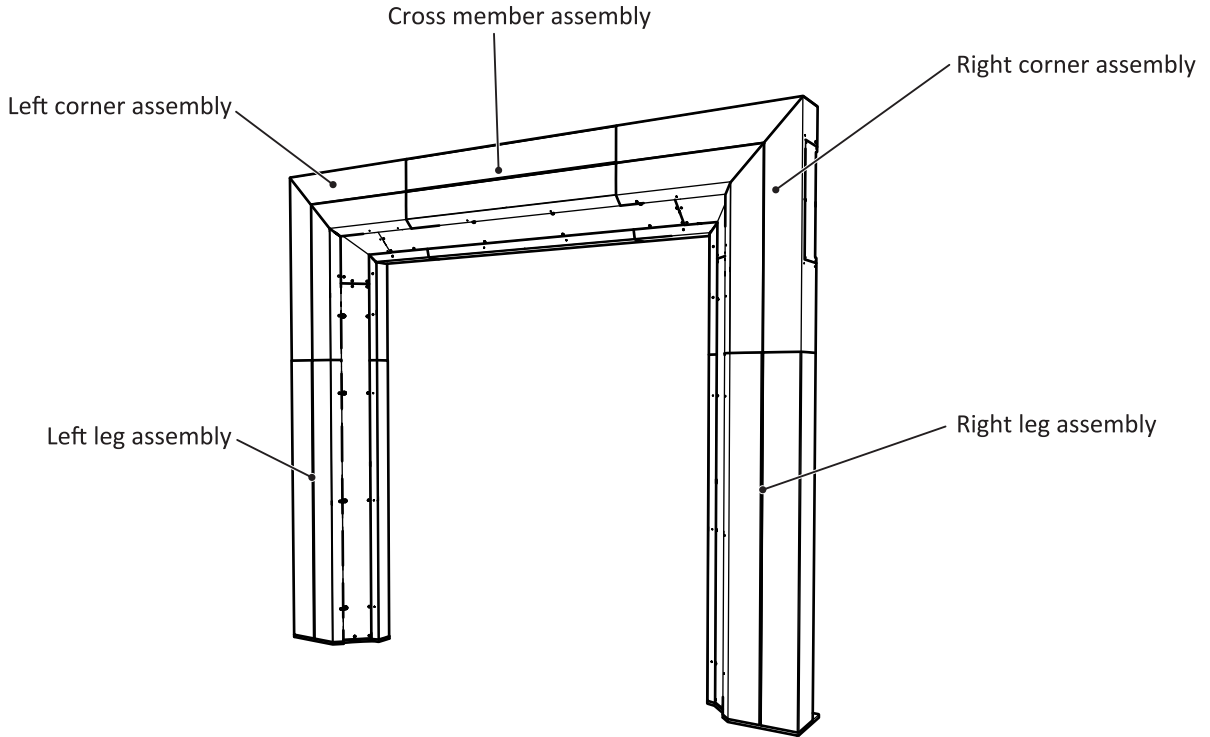

Key Components
 (exploded)

Fig. 15

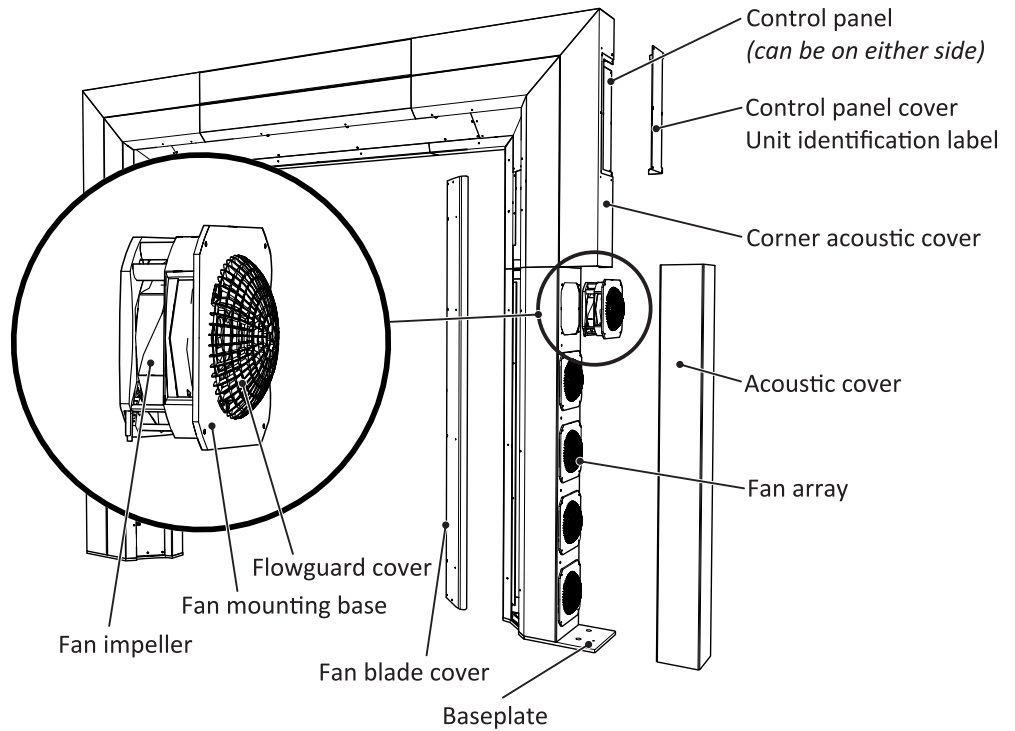

Maintenance 7 Continued

Component Access



Before starting work on the assembly, switch off the supply to the **AirDoor** via the main isolating switch and lock it in the Off position to ensure the power supply remains disconnected.



Work at height must be carried out strictly in accordance with the Work at Height Regulations.

Component Access

Access to key components (fans, controls, etc.) is via removable service panels. Safety fasteners (T20 Security Torx) are used on these service panels, and appropriate bits are required for unit maintenance. Fasteners must be replaced if they show signs of wear.

To inspect the fans or internal wiring looms, or to access the acoustic cover fixings, remove the fan blade cover. Each door has three covers, left, right, and top, an example is shown below. Keep **ALL** fasteners and replace them correctly during reassembly.

Fan blade cover
removal
Fig. 16

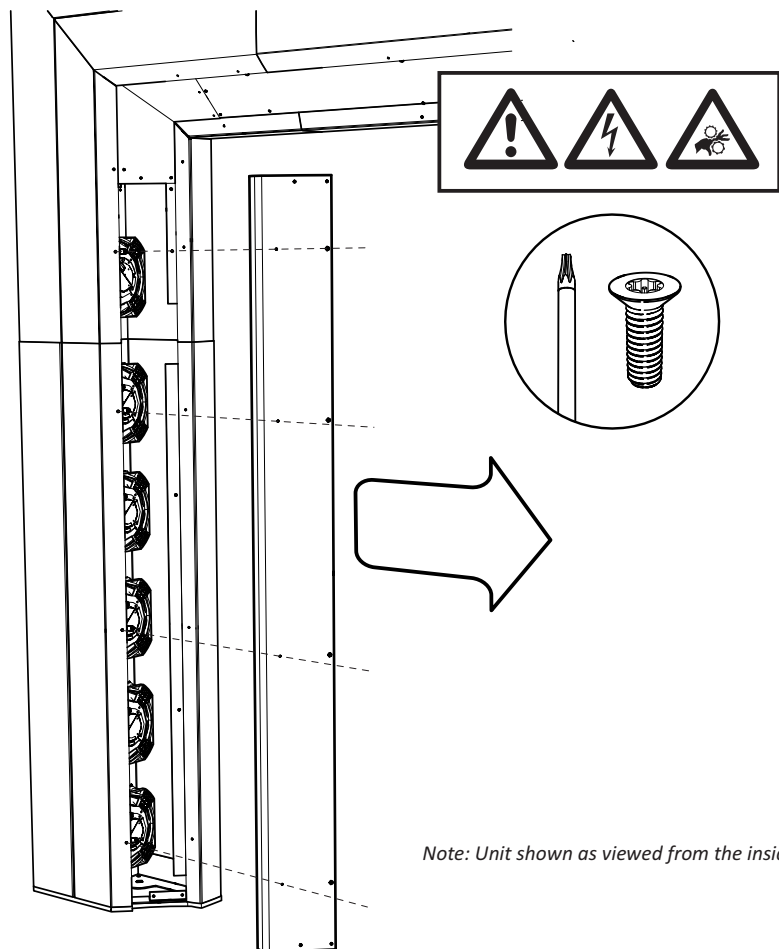

Note: Unit shown as viewed from the inside of the building

Maintenance 7 Continued

Fan Replacement

If a fan replacement is required, the fan must be equipped with Flowguard and power connection before installation.

Please contact the **AirDoor** Team for a suitable replacement fan assembly.

- For fan removal, carefully remove the Fan Blade Service Cover as show in figure 16 .
- **Ensuring the unit is fully isolated**, carefully unplug the appropriate power connector to the fan using the methods illustrated in figure 13 on page 12.
- Remove the Acoustic Cover by removing the ALL the M6 fixings as shown in figure 17 below and the two concealed M12 Hex set screws inside the cover. **Keep all fixings for reassembly later.**

Démontage du
revêtement acoustique
réparations
Fig. 17

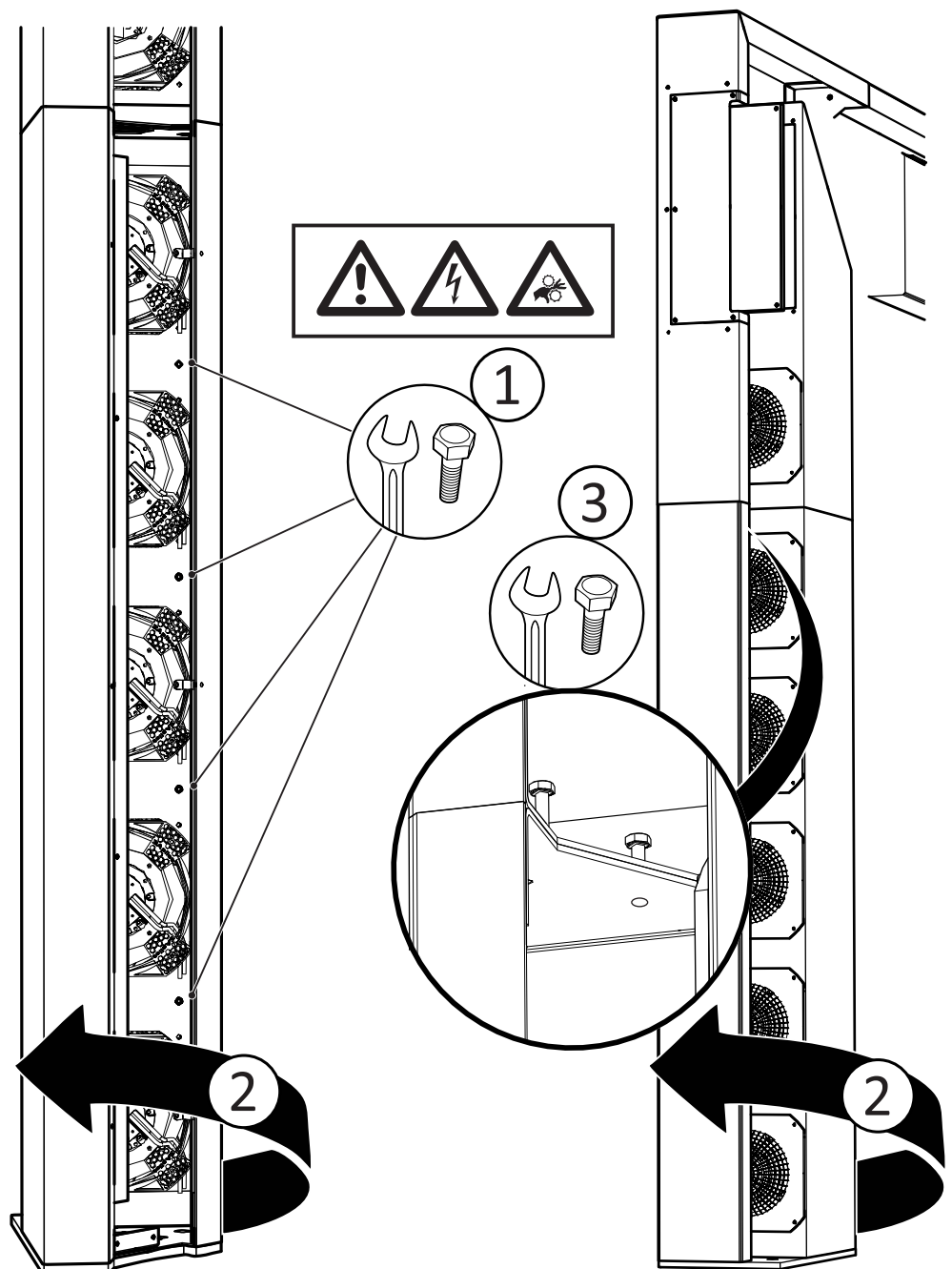

Maintenance 7 Continued

Fan Access

- Carefully remove the acoustic cover.
- Remove the four M4 hexagon socket head fixings from the fan foot inside the acoustic part, as shown in Figure 18 below, and carefully pull the corresponding fan back and out. Pay special attention to the wiring harness.
- Replace in reverse order, again paying attention to the wiring harnesses and ensuring the plug connection is fully made and the plug clips are correctly engaged. Ensure the wiring harness is kept securely away from all moving parts by securing it with cable ties to the designated Z-brackets provided.

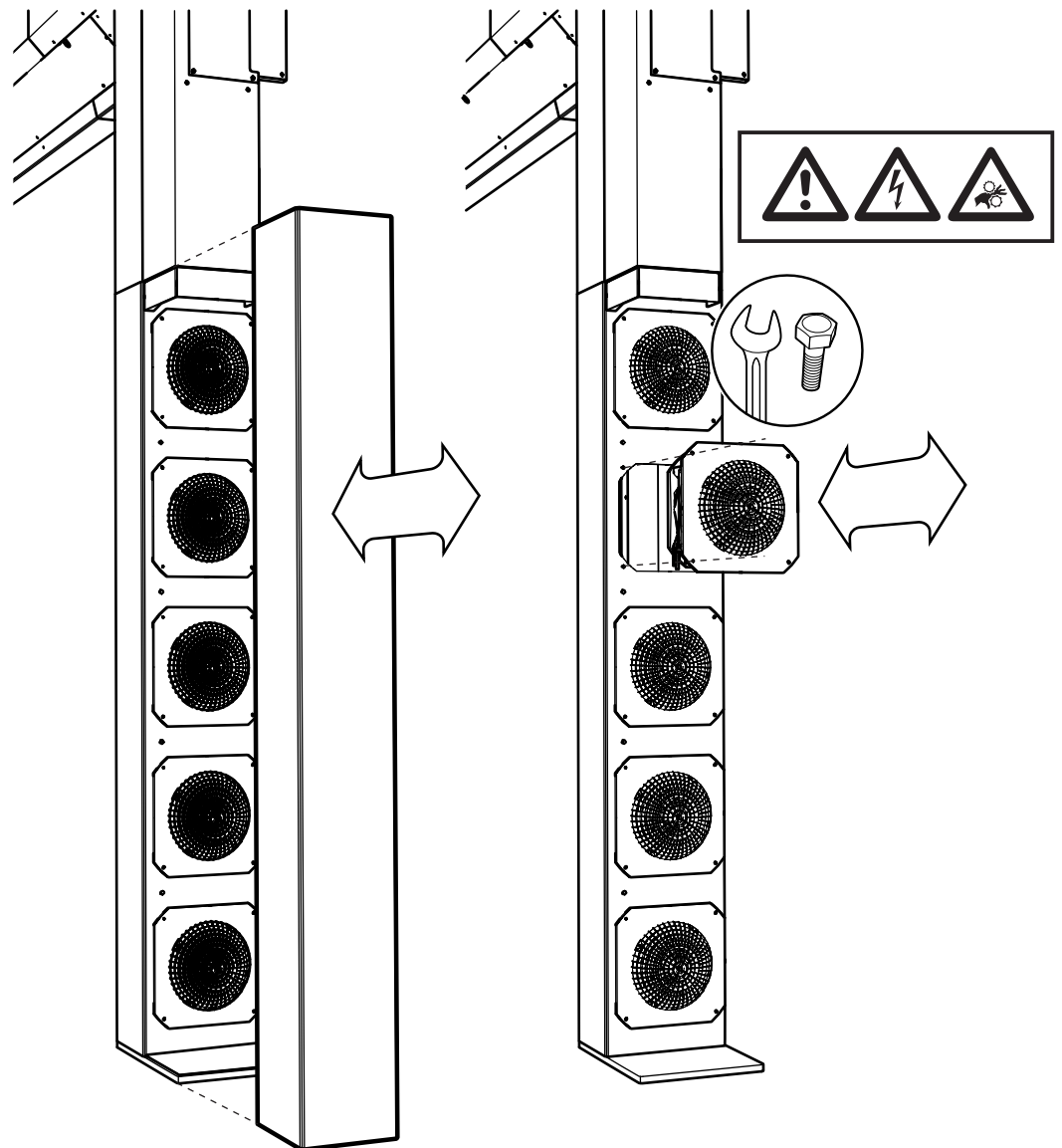

Acoustic Cover
Removal
Fan Out
Fig. 18

Caution



Ensure all plugs are fully connected and assigned to the corresponding fan.
Ensure all wiring harnesses are secured and kept away from all moving parts.
Ensure all fixings and components are correctly and securely reinstalled and all covers are fitted before reconnecting the unit to the mains voltage.

Maintenance

7 Continued

Optimised Predictive Maintenance

The frequency of inspections depends on a number of factors, including proximity to road traffic, pedestrian traffic, air quality, time of year, etc.

It is recommended that after the initial three-monthly inspection, the frequency of inspections is adjusted to achieve optimised periodicity with regard to predictive maintenance; for example, if the fan guards are heavily soiled, the period between inspections may need to be shortened. Conversely, if the fan guards are relatively clean, the inspection period can be extended, monitored, and adjusted accordingly.

Recommended Checks

To keep the **AirDoor™** in good condition, the following maintenance routine is recommended:

Three Monthly Checks

Check that all fan wiring within the unit is secure and undamaged, and shows no signs of deterioration or dirt accumulation. All cables should be secured within the structure; replace any items securing cables that are not tight, and ensure cables are securely stowed away from all moving parts.

Check fan fixings for signs of corrosion, deterioration, or movement.

Cleaning

Inspect and clean the air outlets, fan intake covers, and main surfaces. Use suitable cleaning equipment to remove dust and grease from surfaces. Check all fan inlet grilles for signs of dirt accumulation. Remove stubborn dirt with a dry, stiff brush if necessary.

Caution



Failure to keep the air path clean and free from obstructions is likely to result in reduced performance, noise generation, or fan failure.

Pressure sensor node check

Check the condition and function of the pressure sensors. The pressure sensor nodes should be clean, securely attached, and undamaged. If visible, check that the hose is securely connected to the pressure node and the sensor pot. The sensors should respond quickly to pressure applied to the node. A positive pressure correlates with higher pressure outside the building. The pressure can be monitored via HMI, cloud interface, or if the **AirDoor™** is switched on, increased pressure will normally increase the fan speed.

Twelve Monthly Checks

Check all painted parts to ensure they have not deteriorated, especially where adverse environmental conditions prevail. Repaint if necessary. Matching paint can be supplied on request.

Spare Parts & Repairs

For spare parts inquiries or orders, contact the **AirDoor** Spare Parts Department and quote the sales order number (SO number) and the unit type on the unit's rating plate.

Tel : (+44) 2380 461150

WEEE Directive



At the end of their useful life, the packaging and the product must be disposed of through a suitable recycling facility. Do not dispose of with normal household waste. Do not incinerate.

European Authorised Representative

Comply Express Unipessoal LDA
StartUp Madeira - EV141, Campus da Penteadá, 9020-105Funchal, Madeira, Portugal

PLEASE ENSURE THIS DOCUMENT IS PASSED TO THE END USER



AirDoor™

Active Comfort Solutions

Operation & Maintenance Manual

in partnership
with 
wirthresearch

©VES Andover Ltd. 2026
VES is a trading name of VES Andover Ltd.
Registered in England No. 02303719.
Registered Office as above.



Eagle Close, Chandlers Ford Industrial Estate, Chandlers Ford, Eastleigh, Hampshire, SO53 4NF
Tel : +44 (0) 2380 46 11 50 email : operations@airdoor.co.uk web : www.airdoor.co.uk

VES Ref. ID. VES-DSG-0008
May 2026
Issue: 07
Original Instructions



UK Declaration of Conformity

This declaration is issued under the sole responsibility of the product manufacturer.

Product: AirDoor Units
Type: AIR
Manufacturer: VES Andover Ltd.
Date: 17th November 2022

The object of the declaration described above is in conformity with the relevant UK Statutory Instruments and their amendments:

2016 No. 1091 The Electromagnetic Compatibility Regulations
2008 No. 1597 The Supply of Machinery (Safety) Regulations 2008

We hereby declare that the product described above, to which this declaration of conformity refers to, is in conformity with the essential requirements of the following standards:

BS EN ISO 12100:2010 Safety of machinery - General principles for design - Risk assessment and risk reduction
BS EN ISO 13857:2019 Safety of machinery. Safety distances to prevent hazard zones being reached by upper and lower limbs
BS EN IEC 61000-6-4:2019 Electromagnetic compatibility (EMC) - Generic standards
BS EN 61000-3-3:2013+A2:2021 Electromagnetic compatibility (EMC)-Limits
BS EN 61000-6-2:2005 Electromagnetic compatibility (EMC). Generic standards - Immunity for industrial environments
BS EN 60204-1:2018 Safety of machinery — Electrical equipment of machines

Name:	Signature	Position of Signatory:
A. Reade		Director
J. Attack		Head of Design



EU Declaration of Conformity

This declaration is issued under the sole responsibility of the product manufacturer.



Product: AirDoor Units
Type: AIR
Manufacturer: VES Andover Ltd.
Date: 1st September 2023

The product above is produced in accordance with EC Council Directives:

2004/108/EC The Electromagnetic Compatibility (EMC) Directive
2006/42 EC The Machinery Directive

We hereby declare that the product described above, to which this declaration of conformity refers to, is in conformity with the essential requirements of the following standards:

BS EN ISO 12100:2010 Safety of machinery - General principles for design - Risk assessment and risk reduction
BS EN ISO 13857:2019 Safety of machinery. Safety distances to prevent hazard zones being reached by upper and lower limbs
BS EN IEC 61000-6-4:2019 Electromagnetic compatibility (EMC) - Generic standards
BS EN 61000-3-3:2013+A2:2021 Electromagnetic compatibility (EMC)-Limits
BS EN 61000-6-2:2005 Electromagnetic compatibility (EMC). Generic standards - Immunity for industrial environments
BS EN 60204-1:2018 Safety of machinery — Electrical equipment of machines

Name:	Signature	Position of Signatory:
A. Reade		Director
J. Attack		Engineering Director

