

ecovent[®]
heat recovery

Counterflow Heat Recovery Units

Operation & Maintenance Manual



Eagle Close, Chandlers Ford Industrial Estate, Chandlers Ford, Eastleigh, Hampshire, SO53 4NF

Tel: +44 (0) 2380 46 11 50

email: info@ves.co.uk

web: www.ves.co.uk

VES Ref. ID. VES-DSG-0042
Issue 01
May 2026
Original Instructions

Conventions

Important  This manual must be read in full before Installation, Operation and Maintenance of the units supplied

Please ensure that this document is passed to the end user. This manual forms an integral part of the product and should be kept for the working life of the product. Additional copies of this and supporting documents are available by contacting VES or by visiting www.ves.co.uk and following the 'Download O & M's' link.

The following symbols used within this document refer to potential dangers, advice for safe operation or important points of reference

Warning  Indicates hazards associated with electric current and high voltages

Caution  Indicates hazards that require safety advice for personnel or potential unit/property damage

Important  Indicates important information

Contents		page
1	Introduction	2
2	Nomenclature	3
3	Receipt of Goods & Handling	4
4	Installation	4
5	Standard Wiring & Fan Installation	9
6	Controls Setup	11
7	Maintenance	19

Introduction 1 The ecovent® **midi** series is a range of Heat Recovery units, with duties up to 0.55 m³/s. Suitable for either plantroom, ceiling void or internal locations. As standard, each unit will have been supplied pre-wired to a fitted control panel, as specified at the time of order. The standard operating temperature of these units is -20 to +40 °C.

For further technical details regarding dimensions and weights, contact VES on **02380 461150**, quoting the sales order (SO) number and the unit type as found on the unit nameplate, or alternatively visit www.ves.co.uk.

Nomenclature 2

Part Number Coding

Point Description	Point Variants	Details (as appropriate)
1 Product	EV	Ecovent® Heat Recovery Units
2 Heat Recovery type	CM	midi Series (<i>Counterflow plate heat exchanger</i>)
3 Unit Size	4...5	Sequential see unit outline for details
4 Fan Type	2...8	Centrifugal EC fan
5 Fan Size	2...7	Sequential
6 Phase	-1	230V 50Hz Single Phase
7 Unit Configuration	/FP	Flat Plantroom
8 Main Heating	Null	No Heating
9 Handing <i>(denotes position of supply airflow LIDSAF)</i>	/LT /RT /LB /RB	Left/Top Access Right/Top Access Left/Bottom Access Right/Bottom Access
10 Main Filter	Null /G4 /F7	No filter G4 (Coarse 65%) Pleated filter * F7 (ePM 1 55%) Rigid Pleated Filter *
11 Control Panel Section	/CP	Fitted control panel
12 Colour	Null /R7004	Galvanised finish Powdercoated finish, RAL7004 etc...
13 Finish	Null MT SG FG	Leatherette Matt Satin Gloss Full Gloss
14 Powder Coat Type	Null /IT /BT /S	As colour Internal powdercoated only Internal/External powdercoated Special (non-standard) Unit
15 Special		

* BS EN ISO 16890 classification

Typical Example

EVCM422-1/FP/DS/LB/G4/CPSC/R9010LT

EV CM 4 2 2 -1 /FP /LB /G4 /CP/R9010

① ② ③ ④ ⑤ ⑥ ⑦ ⑧ ⑨ ⑩ ⑪ ⑫ ⑬ ⑭ ⑮

Receipt of Goods & Handling

3 Immediately upon receipt of goods, check for possible damage in transit paying particular attention to fan impellers, drain connections and unit casing. Prior to installation please check to ensure alignment and smooth rotation of the impeller after transit. Also check to ensure that any ancillary items are included. These will normally be supplied fitted or, in the case of small items, taped to the unit.
In the event of any damage having occurred or if any item is found to be missing, it is essential to inform VES Andover Ltd. within **7 days** of delivery quoting sales order number and the unit type, as found on the unit nameplate. After this period, VES would be unable to accept any claim for damaged or missing goods.

Installation

4 The entire system must be considered for safety purposes and it is the responsibility of the installer to ensure that all of the equipment is installed in compliance with the manufacturer’s recommendations, with due regard to the current HEALTH AND SAFETY AT WORK ACT and conforms to all relevant statutory regulations.
Where a unit is installed so that a failure of components could result in injury to personnel, precautions should be taken to prevent such an injury. If the unit is installed where there is a reasonable possibility of persons or objects coming into contact with the impeller whilst operational, a guard should be fitted or steps taken to prevent this. It is the installer’s responsibility to ensure that access panels are not obstructed in any way and safe working access for maintenance must be provided in accordance with Health and Safety and Building Regulations. For confirmation of required access please see the appropriate unit outline drawing.
Consideration must also be given by the installer for adequate illumination of the unit location in order for safe maintenance. Further consideration should be given to the unit’s position and secured into place as appropriate.

Caution  Mounting hangers, door furniture, isolators etc. extend beyond the casework and so are vulnerable to accidental damage. Take necessary precautions so as not to cause damage whilst handling the unit.

The weight of each unit/section is specified on the outline drawing and the total unit weight will be displayed on the unit inspection label. When lifting the unit using a fork lift truck ensure the whole unit is supported by the full length of the forks. It may be necessary to use fork extensions to fully support the unit properly. The centre of gravity may be offset from the centre of the unit; this needs to be taken into consideration when lifting the unit.

Fork Lifting Detail
Fig. 1

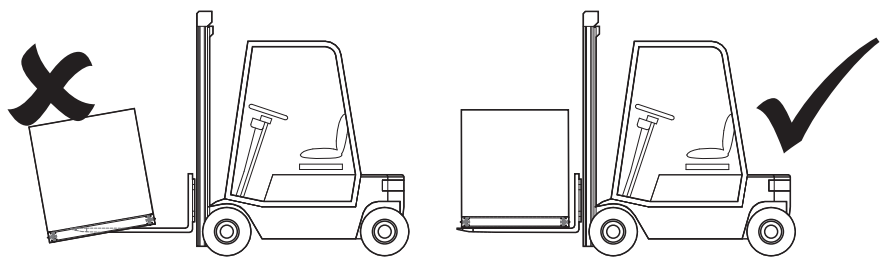

Caution  Handle with care. Failure to fully support the unit during lifting may result in damage to the unit.

Lifting Detail
Fig. 2

Units are to be rigged and lifted using spreaders, taking into account the weight of the unit, and lifting gear should be arranged so as not to bear on the casework see right.

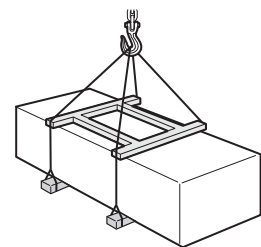

Installation 4 Continued

ecovent® **midi** units are supplied with feet suitable for ceiling-void mounting, by use of drop-rod mounting, in bottom or top access orientation, with airflow in the horizontal plane. For alternative mounting please consult your outline drawing as supplied with the unit, or refer to VES Customer Services for further information. Secure drop rods/unit with the appropriate fixings as shown below **3**.

Unit mounting detail
Fig. **3**

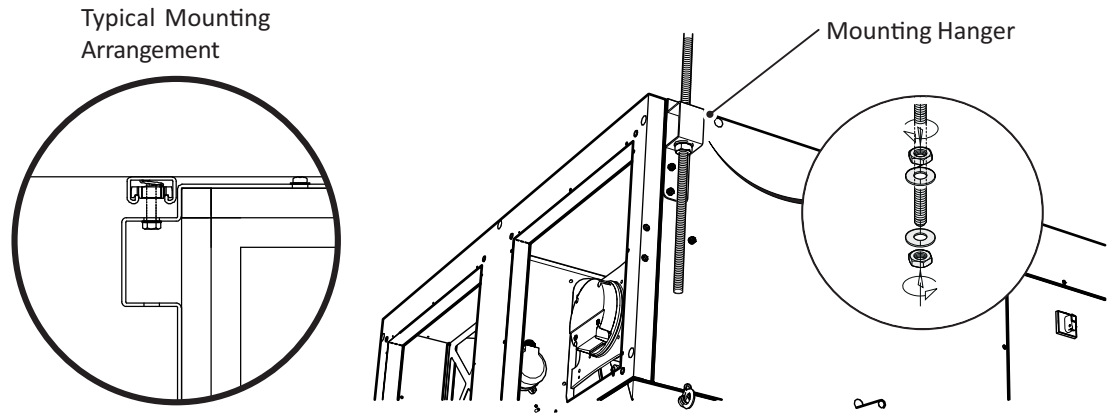

Important  When hanging units from drop-rods, ensure that the load is evenly spread and that **ALL** feet are used within the support, including those for fitted silencers if included. Ensure that the drop rod used is selected appropriately to accommodate the load of the unit. Please consult the unit outline drawing for specific unit weight when choosing suitable fixings.

Section joining detail
Fig. **4**

When units and ancillary modules are supplied separately, it is important that all sections are joined together securely prior to positioning and installation. This should be assembled using self adhesive rubber tape at the joints prior to assembly to prevent possible air leakage; replace with similar if damaged. Finish the assembly by installing the joint fixings to both parts, brackets are secured to the casework using M6 Pozzi screws. Tighten together using a 6mm hex key, drawing both sections together evenly.



Caution  Joining brackets are **NOT** structural and are included as part of the unit sealing only. When moving assembled units ensure that **ALL** sections are fully supported.

Installation 4 Continued
Access

Caution  Risk of injury due to uncontrolled movement of hinged access doors. Ensure the AHU has been given time to come to a complete stop before accessing the unit.

Units in the ecovent® midi range are fitted with hinged access doors to permit access to internal fans and filters for cleaning and maintenance.

- Release the quarter-turn catches using a large flat-bladed screwdriver.
- The access door shall be supported at all times and lowered in a controlled manner.

Each access door is fitted with a safety restraint strap located on the filter side of the unit.

- The safety strap shall not be disconnected until the access door is fully opened and stable.
- Disconnect the restraint strap by releasing the carabiner only when the door is fully supported.

When closing the access door:

- The safety strap shall be reconnected.
- All quarter-turn catches shall be fully engaged and secured before the unit is left unattended.

Important  Where access clearance is restricted and complete removal of the access door from its hinges is required, this task must be carried out in a controlled and safe manner with the door fully supported at all times. Door removal is a two-person operation. Upon completion of work, ensure the access door is correctly refitted and all fixings are fully secured before returning the unit to service.

Unit Access
Fig. 5

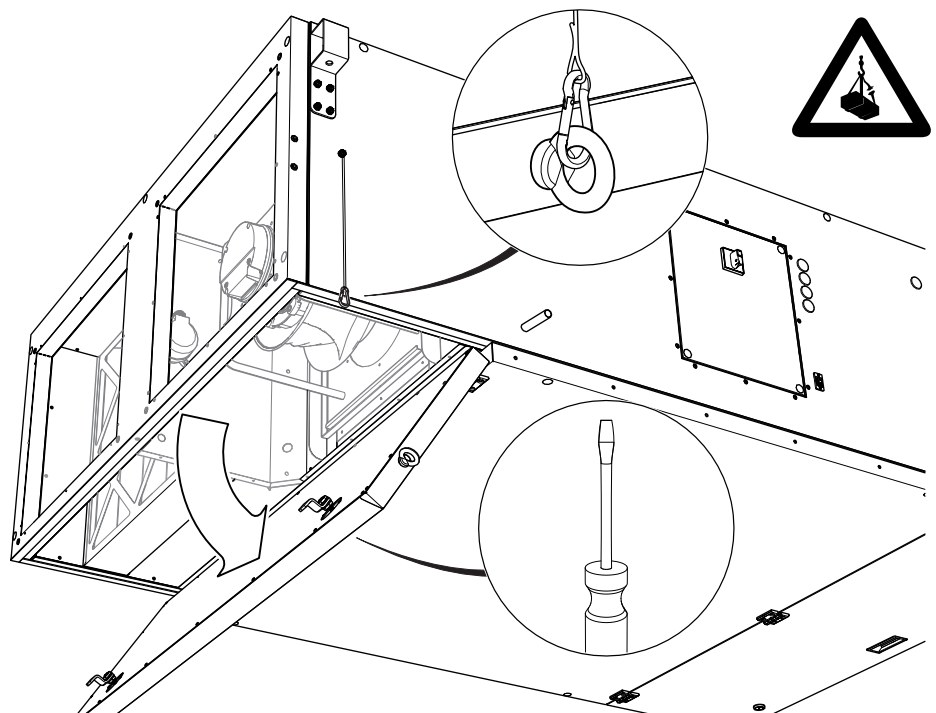

Important  For correct filter access and servicing, please see section 7 Maintenance for full details

Electric Heater
Batteries

For units with ancillary heating please see the appropriate product O&M VES ID Ref. VES-DSG-0010.

Installation 4 Continued

Condensation

The unit is fitted with a drain pan terminated to a Ø15mm external drain spigot. Join using a PVC push-fit straight connector, trap as required and terminate via an appropriate waste system or by use of a peristaltic pump.

Typical Ecovent Drainpan Installation Fig. 6

Shown with access removed for clarity

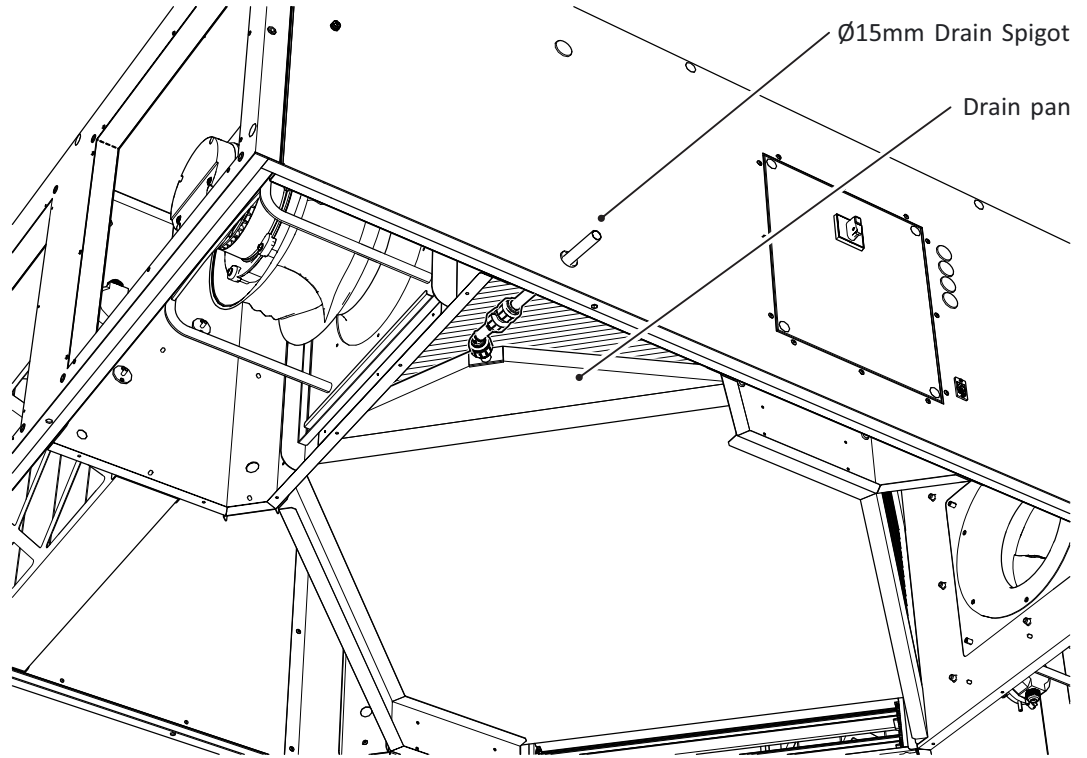

Important



Should it be necessary to access the drainpan for inspection or similar, this is best carried out by removing the extract fan and gaining access through the opening in the fan bulkhead. Please refer to page 21 for details regarding the correct fan removal process.

Typical trapping detail Fig. 7

Drain pan fitted to a heat exchanger, diagrams show situation with fan operational.

Drain to open tundish as shown above.

DIM H = TOTAL STATIC PRESSURE mm Wg + S

S = SAFETY ALLOWANCE 25mm

Example: If H=250Pa (25mm) + safety allowance (25mm) = 50mm

Negative pressure

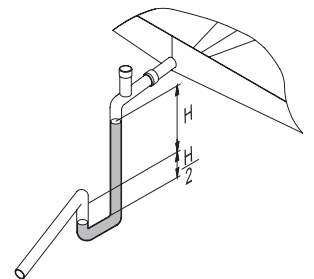

Caution



It is important that the drain be allowed to clear without obstruction. Ensure that the unit is mounted level and the drain pan is angled so that water drains towards the drain spigot as the drain may have moved during transit/installation. Failure to do this may result in excess condensation within the unit and possible flooding.

Installation 4 Continued

**Aftermarket
Condensation
Pumps**

For after market installations, an optional customer-fitted condensate pump kit is available. Fit the appropriate pump/pump sensor to this condensate spigot, mount the pump body as per the manufacturers instruction in a position adjacent to the unit and connect to the appropriate terminals on the control panel as per the panel wiring diagram.



The electrical supply **MUST BE FULLY ISOLATED** before attempting to affect any work on this unit. All electrical connections to any unit must be carried out in accordance with the current edition of the I.E.T. Regulations, only competent Electricians should be allowed to affect any electrical work to our units.

Typical condensate pump connection Fig. 8

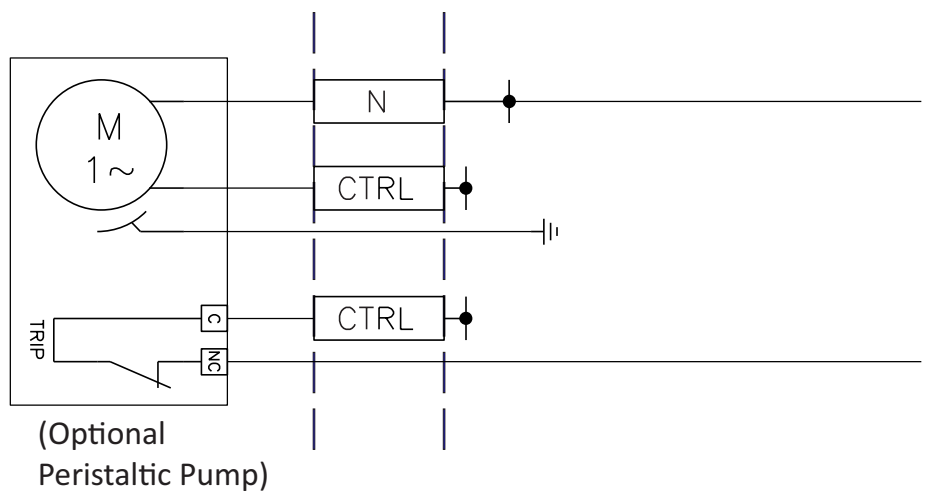



It is important that the drain be allowed to clear without obstruction. Ensure that the unit is mounted level and the drainpan is angled so that water drains towards the drain spigot as the drain may have moved during transit/installation. Failure to do this may result in excess condensation within the unit and possible flooding.



Before the unit is fully operational it is recommended to perform an initial test to confirm the pump and sensor are operating correctly. Ensure that all debris is removed from the condensate drainpan. Manually add enough water to the drain to ensure the pump sensor float switch is activated. Turn the unit on and check the pump starts and stops as the water level decreases.

Standard Wiring & Fan Installation 5

Warning  The electrical supply **MUST BE FULLY ISOLATED** before attempting to affect any work on this unit. All electrical connections to any unit must be carried out in accordance with the current edition of the I.E.T. Regulations, only competent Electricians should be allowed to affect any electrical work to our units.

Important  It is recommended that the cable entry point should be at the side of the unit as shown below in figure 10. It is the responsibility of the installer to ensure that a suitable cable gland (giving adequate protection and strain relief) is fitted, and in doing so also ensure that no internal components are damaged during this installation. Make certain any swarf produced is removed before use. It is the installer's responsibility to supply earth protection through the building installation device and a dedicated, isolated power 220-240VAC 50Hz supply with overload protection, to account for motor start up currents. For specific details see Fig. 9. The installer must provide a switched fused spur. The spur must be a double pole connection point that is local to the unit (the contact separation of the fused spur switch should be at least 3mm).

Warning  Do not connect any unit to an electrical supply voltage outside of the specification.

Standard Fan Details
Fig. 9

EVCN	Size	Phase	Motor Size	Voltage	Fan Speed rpm	Full Load Current	Speed Control
	422-1	1	0.500 kW	230 VAC	3170	2.10 A	EC
	524-1	1	0.780 kW	230 VAC	3110	4.00 A	EC

Recommended cable entry points
Fig. 10

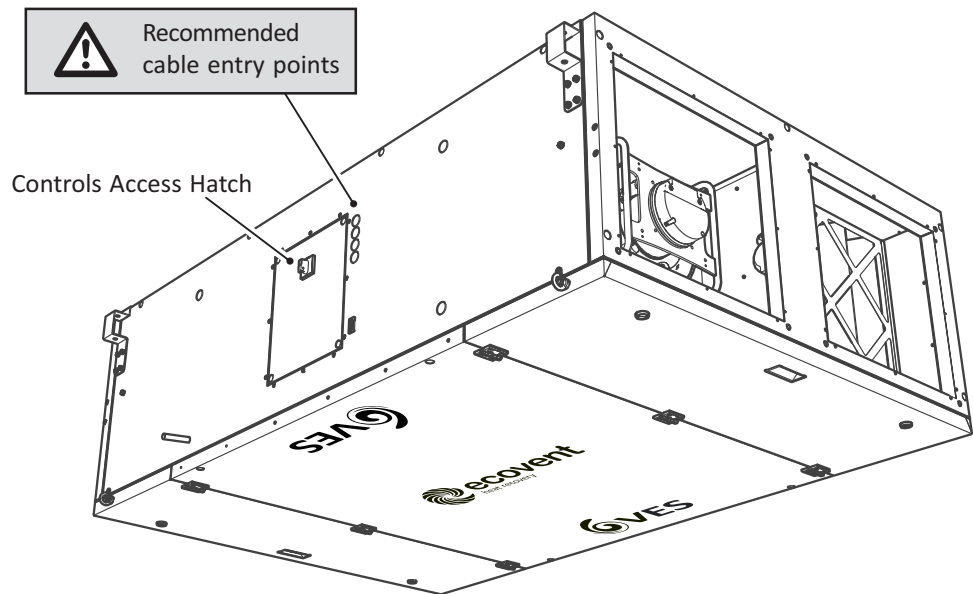

Standard Wiring & Fan Installation 5

Important



For all units with fitted controls and for ancillary items, please see the accompanying wiring diagram for full details or contact VES Customer Services Department on **02380 461150**, quoting the sales order (SO) number and , quoting the sales order (SO) number and unit type as found on the unit name plate.

Important



Prior to commissioning the unit, ensure that all fans rotate freely. If any components have shifted during transportation, verify that they are correctly realigned to allow proper operation and rotation. Carefully rotate the fan by hand to check for any rubbing or interference.

If re-alignment is required, the fan will need to be removed from the unit. Please refer to page 21 for details regarding the correct fan removal process. Support the fan assembly by the fan plate NOT the impellor, noting the labelling on the fan showing TOP. Loosen (do not remove) the fan inlet eye fixings and manually adjust the inlet eye until the clearance between the inlet and the fan is uniform around the circumference. Confirm that the fan rotates freely in the adjusted position, then re-tighten the fixings while holding the inlet eye in position (see Figure 11).

The same inspection should be carried out for all wiring looms. Any wiring that has become loose during transit must be securely fastened and routed clear of all moving components.

Fan alignment details

Fig. 11

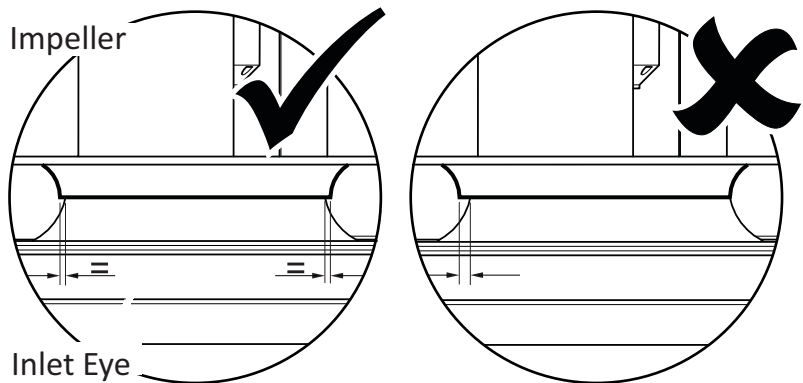
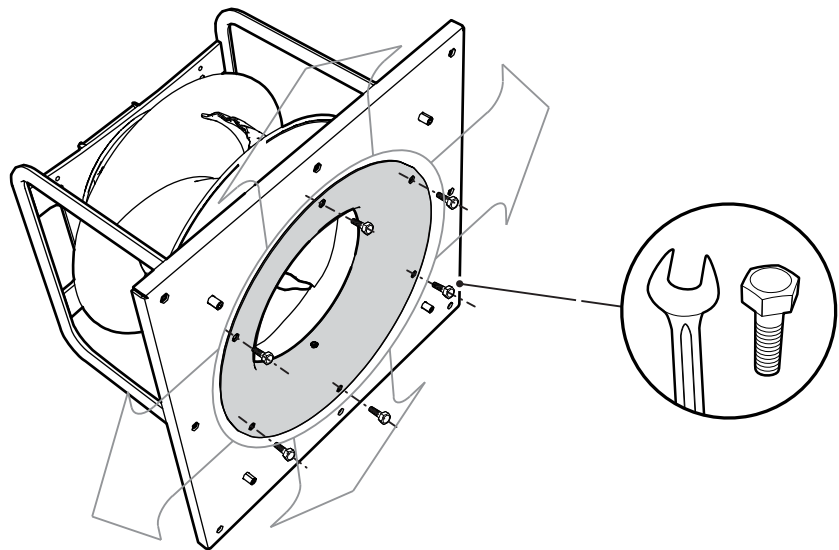

Controls Setup 6

Caution  The following set up should only be undertaken by a competent commissioning engineer. Incorrect adjustment will adversely affect the accuracy and performance of the system

Controls Interface

Although the controls will interface with a building management system (BMS), initial setup can only be completed using a handheld human-machine interface (HMI). There are two versions of HMI available, a roller button version and a six-button version. The button operation is described below but the menu operation is the same for both.

There are two modes of operations available. Read only mode, whereby several parameters may be viewed for a quick visual inspection of the systems current state and Commissioning mode, which allows the user to view and edit all parameters. This includes functions such as adjusting fan speeds, temperature setpoints, heating type and integrated communications settings. Commissioning mode is indicated as the access mode typically by the presence of **3 keys** in the top right-hand corner, in read only mode this will be blank.

HMI Variants
Fig 12

PSEL900461
(Six button HMI)

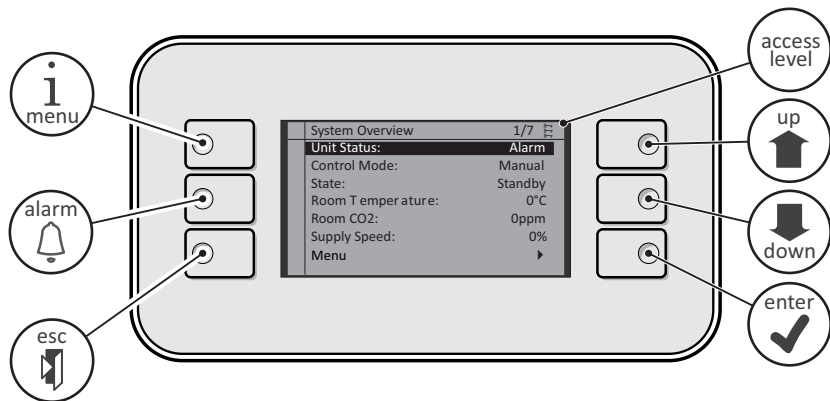

PSEL900463
(Roller button HMI)

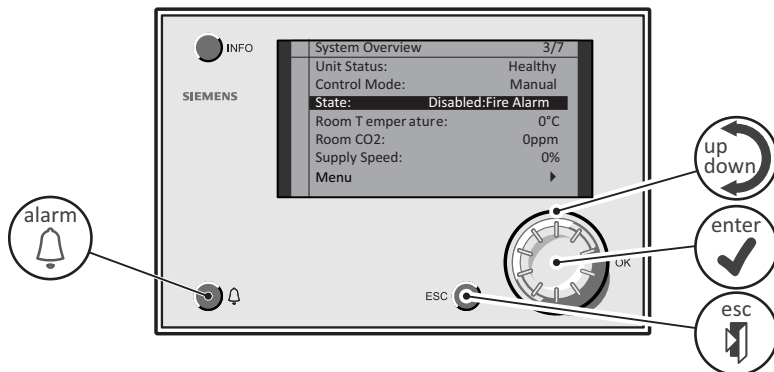

Controls Setup 6 Continued

① Plug the HMI into the RJ45 Socket on to unit as shown. Note: when the HMI is first plugged in, it may take up to 45 seconds before the HMI is ready

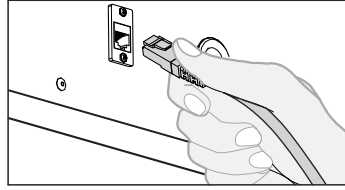

② Using the **up** and **down** buttons on the HMI, move to the **System Switch** field and press **enter**.

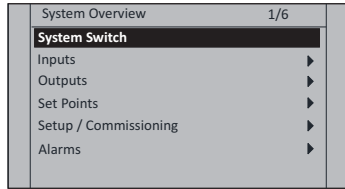

③ Using the **up** and **down** buttons on the HMI, move to the **ON** field and press **enter**.

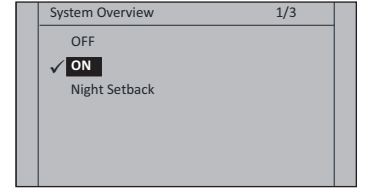

④ The unit should now run, in conjunction with the supply fan and extract fan setpoint parameters.

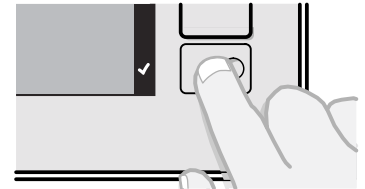

Setting fan speeds

① Plug the HMI into the RJ45 Socket on to unit as shown.

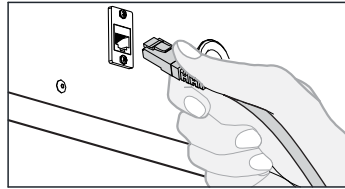

② Using the **up** and **down** buttons on the HMI, move to the **Set Points** field and press **enter**.

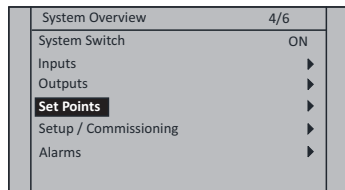

⑦ Using the **up** and **down** buttons on the HMI, move to the **Manual Override** field and press **enter**.

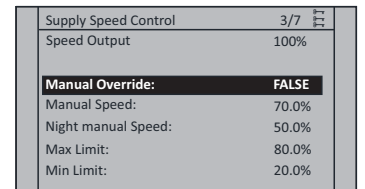

⑧ Using the **up** and **down** buttons on the HMI, move to the **TRUE** field and press **enter**. Press the **escape** button to return to the previous screen.

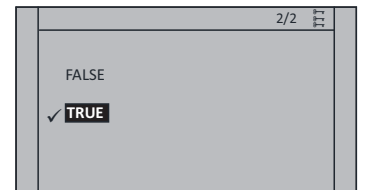

③ Move to **To Edit Enter Password** and press **enter**.

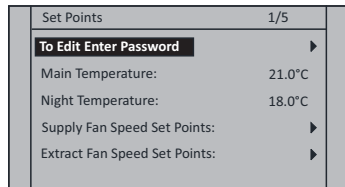

⑨ Using the **up** and **down** buttons on the HMI, move to the **Manual Speed** field and press **enter**.

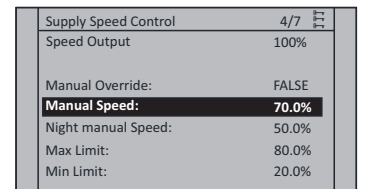

④ Enter password **5973**. This will now return you to the system overview screen. Note: There should be 3 keys in the top right-hand corner to indicate commissioning mode.

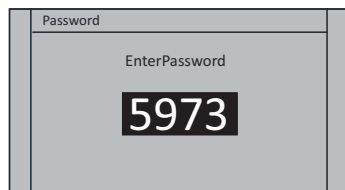

⑩ Using the **up** and **down** buttons on the HMI, adjust the fan speed and measure the unit airflow to achieve the desired duty rate. Press **enter** once complete. Repeat the process for Night Manual Speed; Max Limit and Min Limit as required.

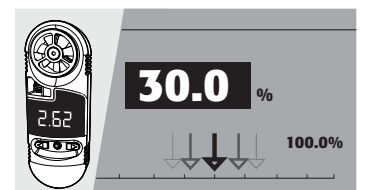

⑤ Using the **up** and **down** buttons on the HMI, move to the **Set Points** field and press **enter**.

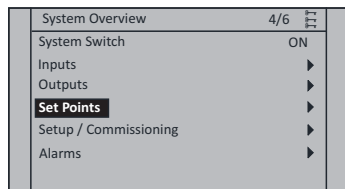

⑪ Once complete, **long press** the **enter** button and press **enter** to log off.

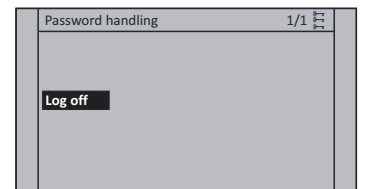

⑥ Using the **up** and **down** buttons on the HMI, move to the **Supply Fan Speed Set Points** and/or **Extract Fan Speed Set Points** field and press **enter**.

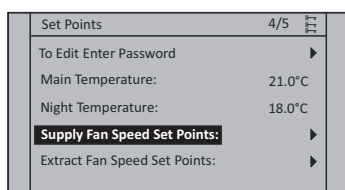

Controls Setup 6 Continued Selecting Heating Type

① Plug the HMI into the RJ45 Socket on to unit as shown.

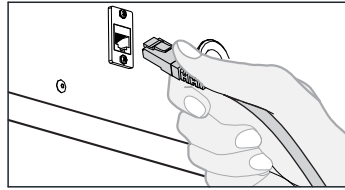

② Using the **up** and **down** buttons on the HMI, move to the **Setup / Commissioning** field and press **enter**.

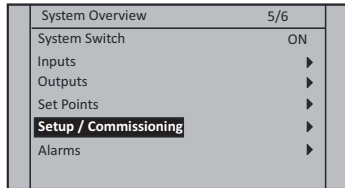

③ Move to **To Edit Enter Password** and press **enter**.

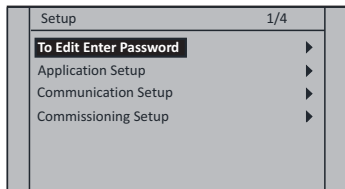

④ Enter password **5973**.
Note: There should be 3 keys in the top right-hand corner to indicate commissioning mode.

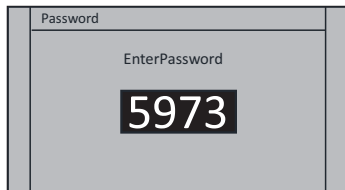

⑤ Using the **up** and **down** buttons on the HMI, move to the **Setup/Commissioning** field and press **enter**.

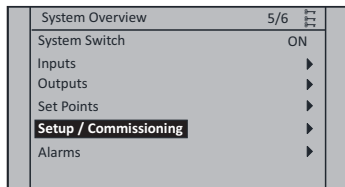

⑥ Using the **up** and **down** buttons on the HMI, move to the **Application Setup** field and press **enter**.

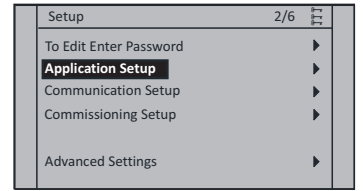

⑦ Using the **up** and **down** buttons on the HMI, move to the **Heating** field and press **enter**.

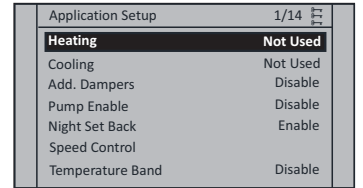

⑧ Using the **up** and **down** buttons on the HMI, move to the desired heating type as required and press **enter**.
Note: the system will utilise the heat recovery device in the first instance. If ancillary heating has been installed, this will top up the heat according to demand.

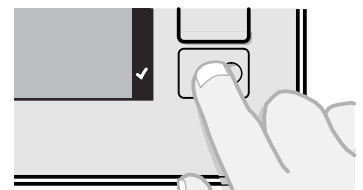
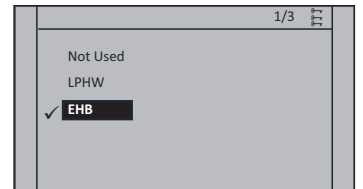

⑨ Once complete, **long press** the **enter** button and press **enter** to **log off**.

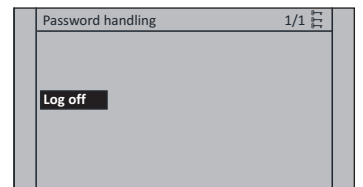

Controls Setup 6 Continued Setting Temperature Set Points

① Plug the HMI into the RJ45 Socket on to unit as shown.

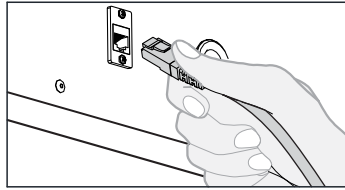

② Using the **up** and **down** buttons on the HMI, move to the **Set Points** field and press **enter**.

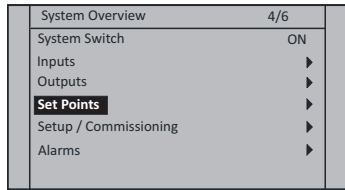

③ Move to **To Edit Enter Password** and press **enter**.

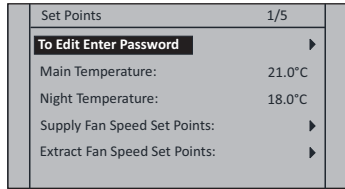

④ Enter password **5973**. This will now return you to the system overview screen.

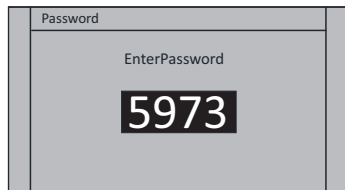

⑤ Using the **up** and **down** buttons on the HMI, move to the **Set Points** field and press **enter**.

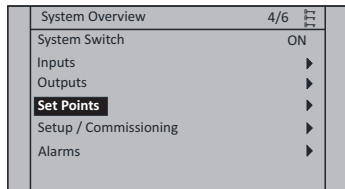

⑥ Using the **up** and **down** buttons on the HMI, move to the **Main Temperature** field and press **enter**.

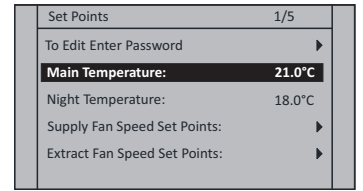

⑦ Using the **up** and **down** buttons on the HMI, adjust the temperature to achieve the desired set point. Press **enter** once complete.

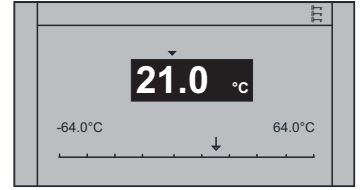

Note: the system will utilise the heat recovery device in the first instance. If ancillary heating has been installed, this will top up the heat according to demand.



Repeat the process for Night Temperature as required.

⑧ Once complete, **long press** the **enter** button and press **enter** to **log off**.

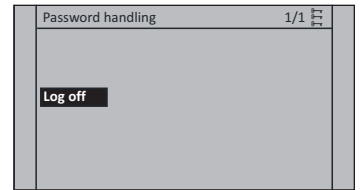

Controls Setup Communications Settings

6 Continued

① Plug the HMI into the RJ45 Socket on to unit as shown.

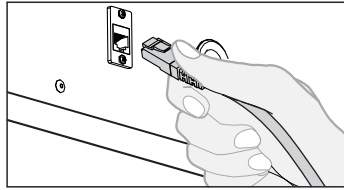

② Using the **up** and **down** buttons on the HMI, move to the **Setup/Commissioning** field and press **enter**.

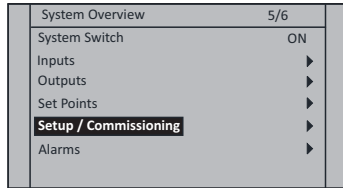

③ Move to **To Edit Enter Password** and press **enter**.

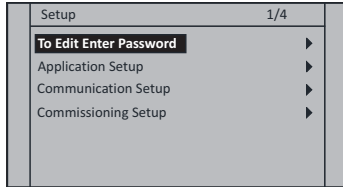

④ Enter password **5973**. This will now return you to the system overview screen.

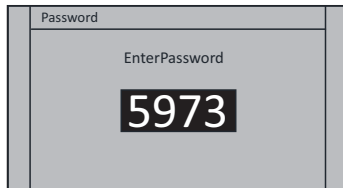

⑤ Using the **up** and **down** buttons on the HMI, move to the **Setup/Commissioning** field and press **enter**.

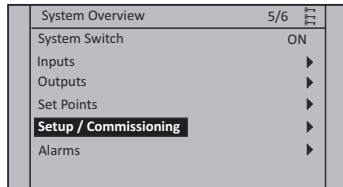

⑥ Using the **up** and **down** buttons on the HMI, move to the **Communication Setup** field and press **enter**.

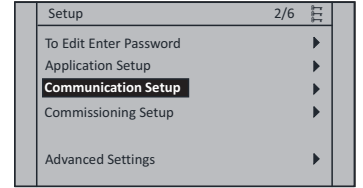

⑦ Using the **up** and **down** buttons on the HMI, select either **Modbus** or **BACnet** and press **enter**. Adjust settings as appropriate.

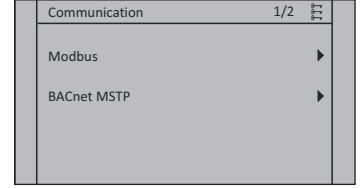

⑧ Once complete, **long press** the **enter** button and press **enter** to **log off**.

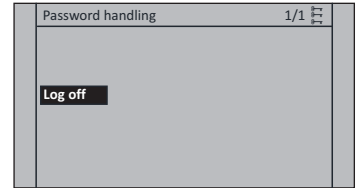

Controls Setup 6 Continued Pump Enable

① Plug the HMI into the RJ45 Socket on to unit as shown.

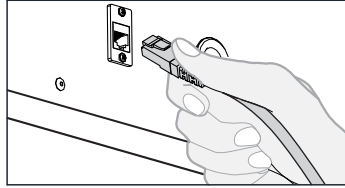

② Using the **up** and **down** buttons on the HMI, move to the **Setup / Commissioning** field and press **enter**.

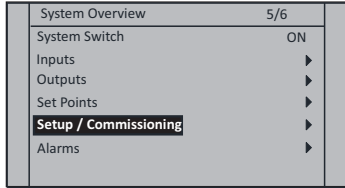

③ Move to **To Edit Enter Password** and press **enter**.

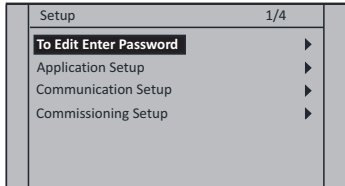

④ Enter password **5973**.
Note: There should be 3 keys in the top right-hand corner to indicate commissioning mode.

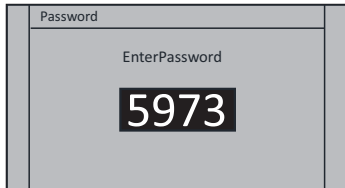

⑤ Using the **up** and **down** buttons on the HMI, move to the **Setup/Commissioning** field and press **enter**.

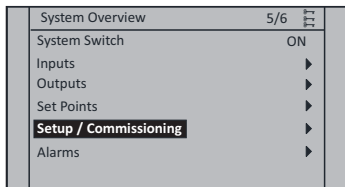

⑥ Using the **up** and **down** buttons on the HMI, move to the **Application Setup** field and press **enter**.

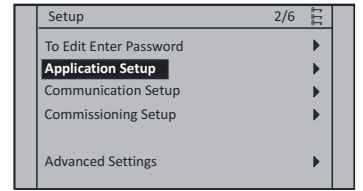

⑦ Using the **up** and **down** buttons on the HMI, move to the **Pump Enable** field and press **enter**.

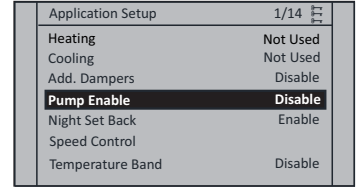

⑧ Using the **up** and **down** buttons on the HMI, move to the desired field type as required and press **enter**.

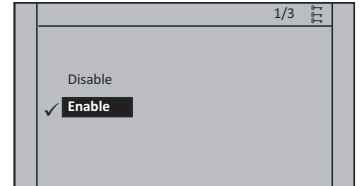

⑨ Once complete, **long press** the **enter** button and press **enter** to log off.

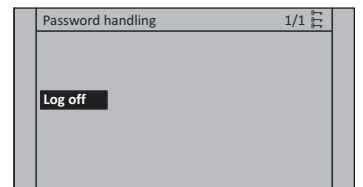

Controls Setup Additional Dampers

6

Continued

① Plug the HMI into the RJ45 Socket on to unit as shown.

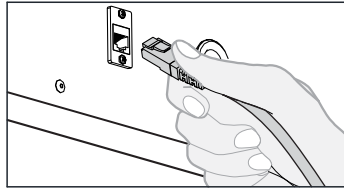

② Using the **up** and **down** buttons on the HMI, move to the **Setup / Commissioning** field and press **enter**.

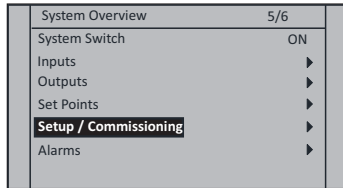

③ Move to **To Edit Enter Password** and press **enter**.

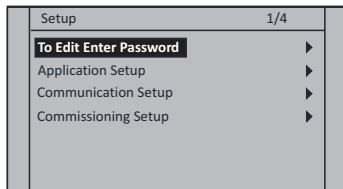

④ Enter password **5973**.
Note: There should be 3 keys in the top right-hand corner to indicate commissioning mode.

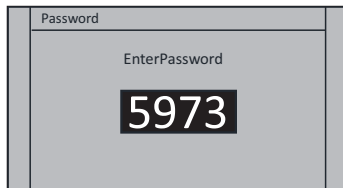

⑤ Using the **up** and **down** buttons on the HMI, move to the **Setup/Commissioning** field and press **enter**.

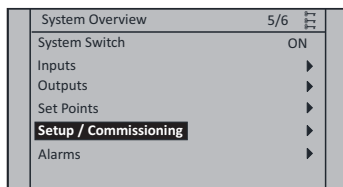

⑥ Using the **up** and **down** buttons on the HMI, move to the **Application Setup** field and press **enter**.

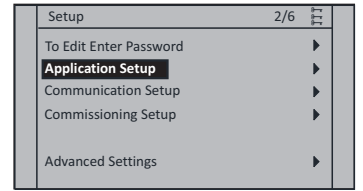

⑦ Using the **up** and **down** buttons on the HMI, move to the **Add. Dampers** field and press **enter**.

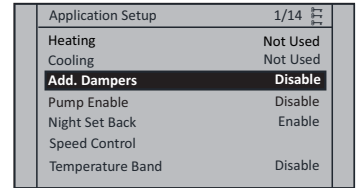

⑧ Using the **up** and **down** buttons on the HMI, move to the desired field type as required and press **enter**.

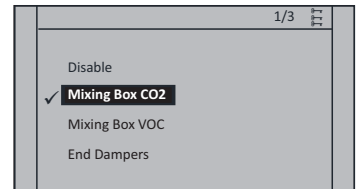

⑨ Once complete, **long press** the **enter** button and press **enter** to **log off**.

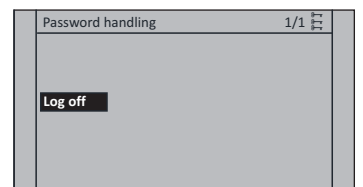
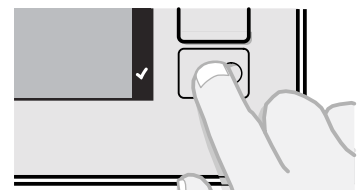

Controls Setup 6 Continued Troubleshooting

① Plug the HMI into the RJ45 Socket on to unit as shown. If the alarm button is illuminated and/or flashing, this indicates a fault within the system. Press **alarm** button to view the details of the fault and act accordingly.

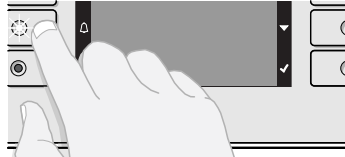
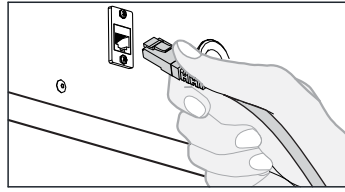

② To acknowledge the alarm, using the **up** and **down** buttons on the HMI, move to the **Alarms** field and press the **enter** button.

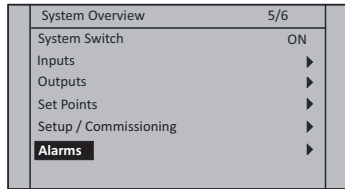

③ Move to **To Acknowledge Enter Password** and press **enter**.

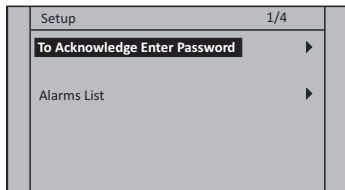

④ Enter password **5973**. This will now return you to the system overview screen.

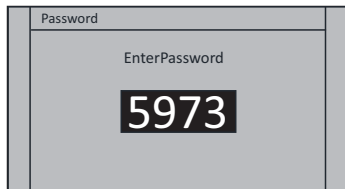

⑤ Using the **up** and **down** buttons on the HMI, move to the **Alarms** field and press the **enter** button.

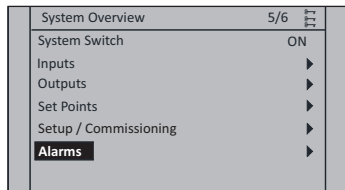

⑥ Using the **up** and **down** buttons on the HMI, move to the **Alarms List** field and press the **enter** button.

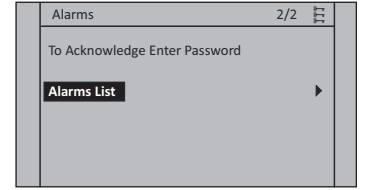

⑦ Using the **up** and **down** buttons on the HMI, move to the **Acknowledge** field and press **enter**.

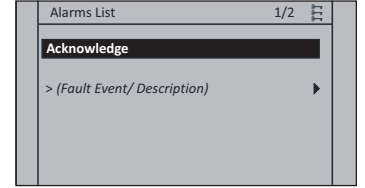

⑧ Using the **up** and **down** buttons on the HMI, move to the **Execute** field and press **enter**.

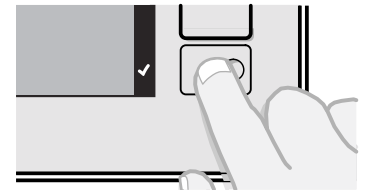
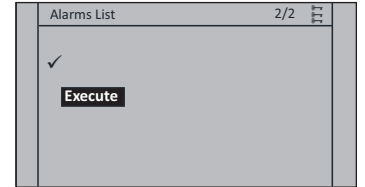

⑨ Once complete, long press the **enter** button and press enter to **log off**.

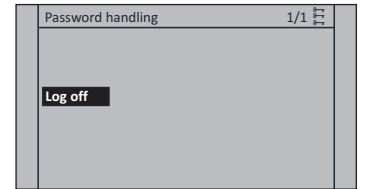

Maintenance 7

Important 

Before attempting to carry out any work on our units, all accompanying documentation including warning labels on the unit must be referenced. Should it be necessary to remove any component ensure that these are secured into position once reinstalled. It is critical that after any maintenance work has been conducted that all components removed/replaced be refitted correctly by a competent engineer.

Warning 

Before attempting to carry out any maintenance work, investigative or repair work on our units, the unit **MUST BE COMPLETELY ISOLATED** from its electrical supply. Ensure a minimum of two minutes after electrical disconnection before removing access panels. This will allow any moving parts to come to a rest. Care should also be taken when accessing external units as the wind and elements may cause moving parts to 'windmill'.

In general, this series of units require little maintenance. In the unlikely event of component failure, spares are available from stock at VES Andover Ltd. See Fig. 19

Caution 

When accessing the unit ensure the access panels are handled/opened in a controlled manner so as to avoid damage to the unit or injury to personnel. This is particularly important with bottom access units. Ensure the AHU has been allowed to completely cool before attempting any work to the unit

For bottom access units, should it be necessary to remove the heat exchanger and/or drainpan assembly from the unit casework please contact VES for further details.

ecovent® midi units feature plug & socket connections to allow easy removal/replacement of key components. Separate the plug connection by hand by pressing the top/bottom clasp mechanism to open

Plug & socket operation
Fig. 13

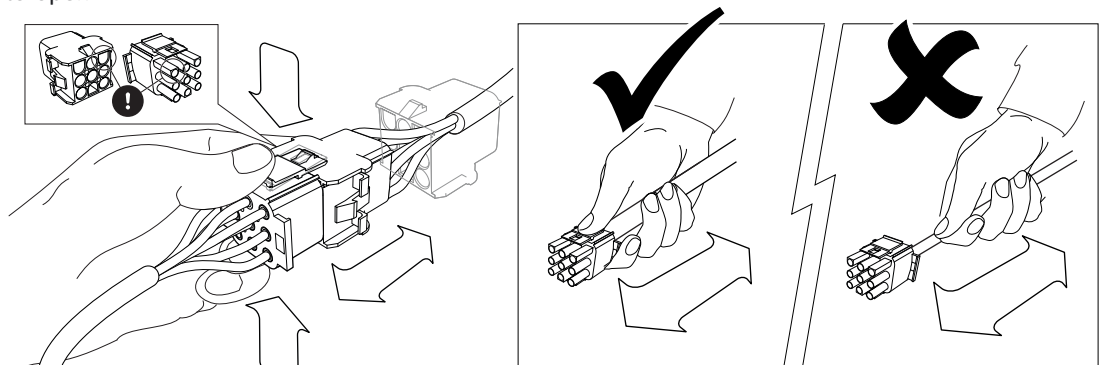

On reconnection, the assembly features a locating lug to ensure correct orientation. Once rejoined, lock the connection together again using the system as shown. Note the plugs are handed and forcing an incorrect connection may result in damage to the plug.

Important 

ecovent® midi units feature plug & socket to all internal electrical components. Each loom is identifiable by a coloured sleeve and printed product code and description. Ensure that when replacing multiple components only the matching looms are reconnected.

Caution 

Gently pull apart the plugs to separate, **DO NOT pull the cables to separate the assembly**

Maintenance 7 Continued

Key Components
EVC4 & 5

Fig. 14

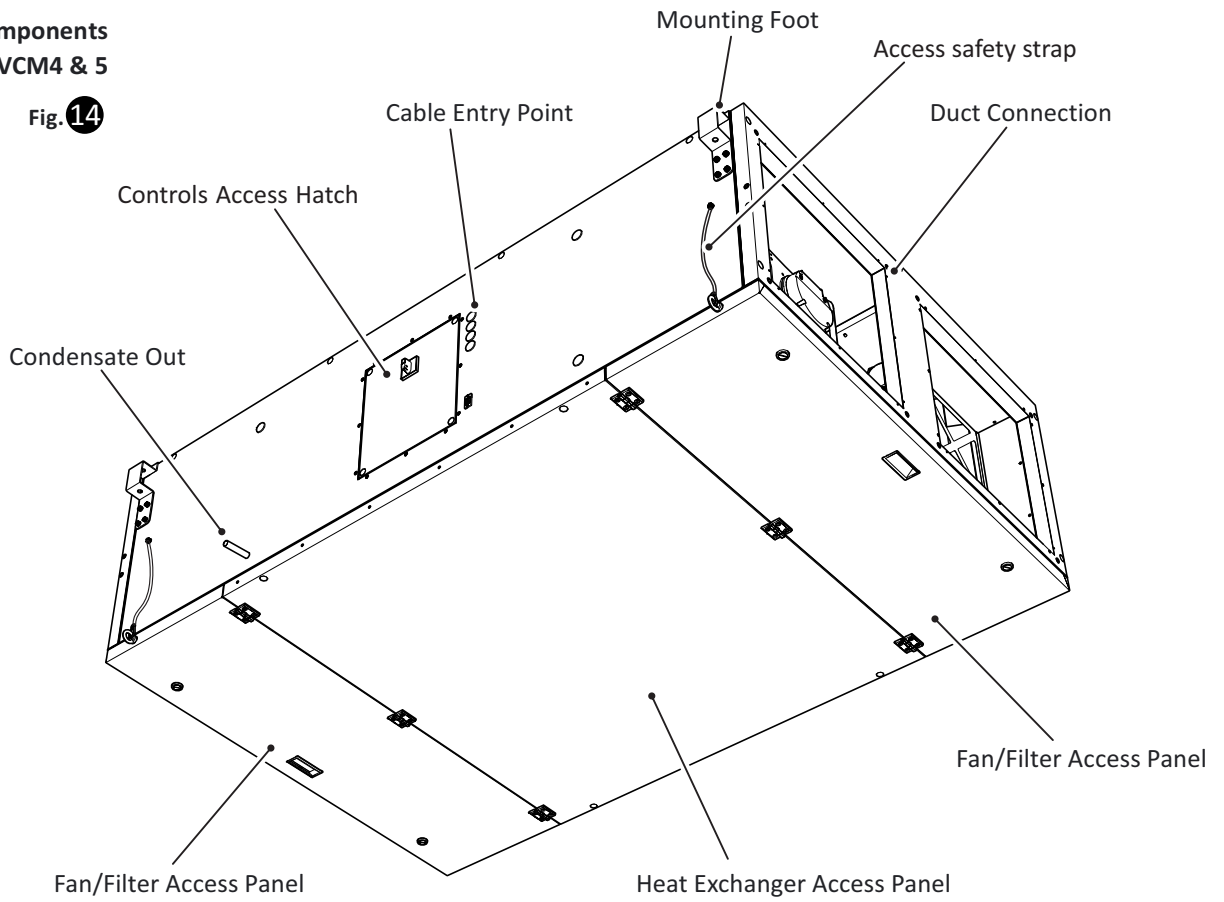
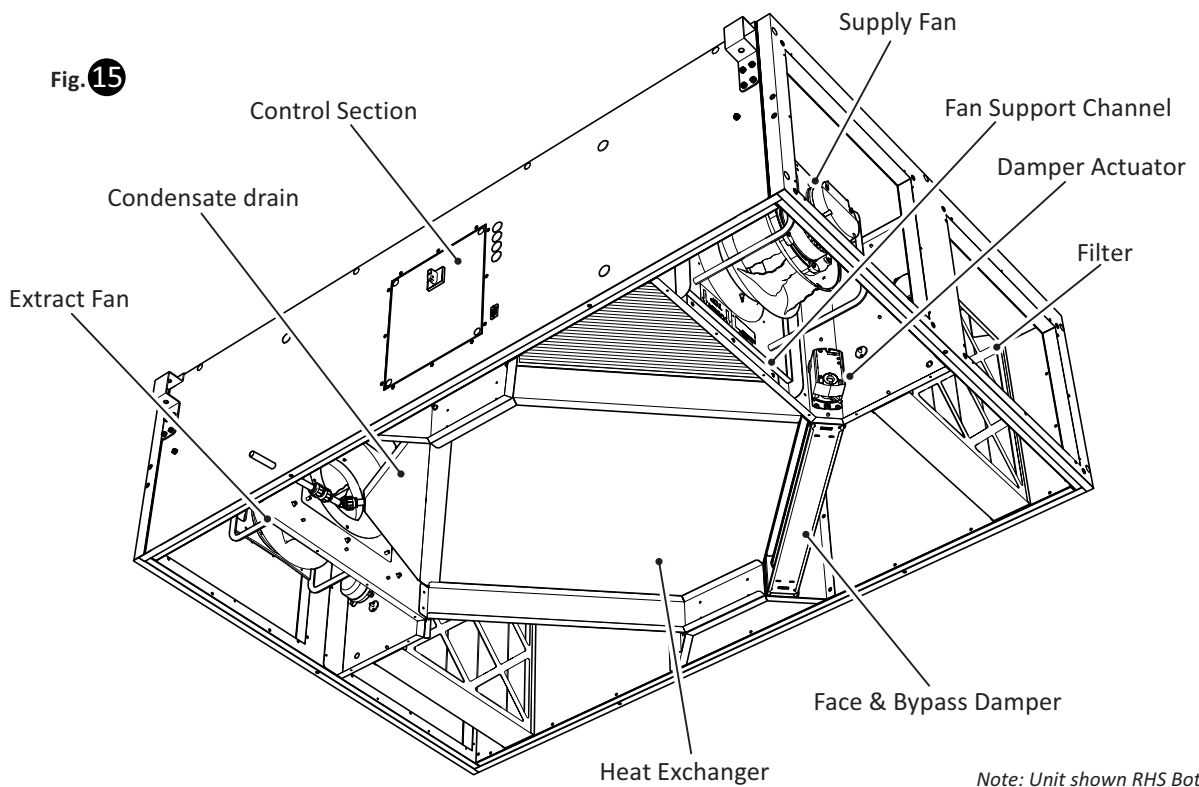

Fig. 15



Note: Unit shown RHS Bottom Access
Bottom Access panel removed for illustrative purposes only

Maintenance 7 Continued

Caution



ecovent® midi units incorporate a bulkhead-mounted fan plate assembly. When removing or refitting components or assemblies on bottom-access units, suitable control measures must be in place to prevent injury and equipment damage. Larger components present a manual handling risk and must be lifted and supported by two or more persons where required. The fan assembly must be adequately supported at all times during removal and installation. Do not remove support or energise the unit until all fixings are correctly installed and fully tightened.

ecovent® midi units are equipped with a single-inlet centrifugal fan mounted within a dedicated support assembly.

Warning



Failure to isolate the unit from the electrical supply may result in serious injury or death due to electric shock.

The fan assembly is not self-supporting once fixings are removed. Failure to adequately support the assembly may result in personal injury or damage to the unit.

Caution



Sharp edges may be present on internal components. Wear suitable protective gloves when handling the fan assembly.

Fan Assembly Removal

Isolate the unit from the mains power supply. Confirm that the unit is fully de-energised. Disconnect the fan plug connector as shown in Fig. 13.

While fully supporting the fan assembly:

- ① Remove the plate fixing screws and retain all fixings.
- ② Swing the assembly away from the fan bulkhead.
- ③ Lift the assembly clear of the fan support channel.
- ④ Carefully slide the assembly out of the unit.

Fan removal
Fig. 16

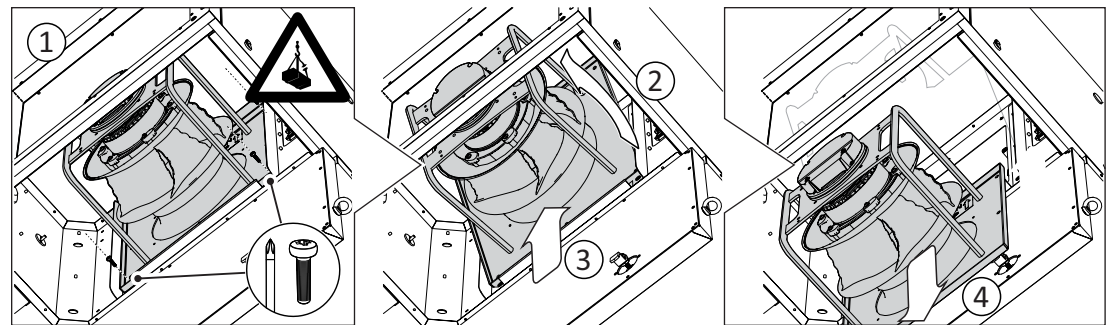

Fan Assembly Refitting

Carefully slide the fan assembly into position within the unit. Engage the assembly fully into the fan support channel. Swing the assembly towards the fan bulkhead. Reinstall and securely tighten all fixing screws. Reconnect the fan plug connector.

Important



Ensure the fan bulkhead is correctly orientated, with the **TOP** marking on the fan plate positioned uppermost, as indicated on the label.

Maintenance 7 Continued

Recommended Checks

In order to keep the unit in good order the following maintenance routine is recommended:

Three Monthly Checks

Filters should be inspected every three months. If they are found to be heavily soiled or damaged in any way they should be replaced. Spare filters can be ordered from VES Spares Department. The filters may be accessed via dedicated access doors on the bottom of the unit. To replace, dispose of the old filters responsibly, note the airflow direction arrow on the new filter. Slide the clean filter into the unit and replace the access doors ensuring all catches are fully engaged.

Unit Access

Fig. 17

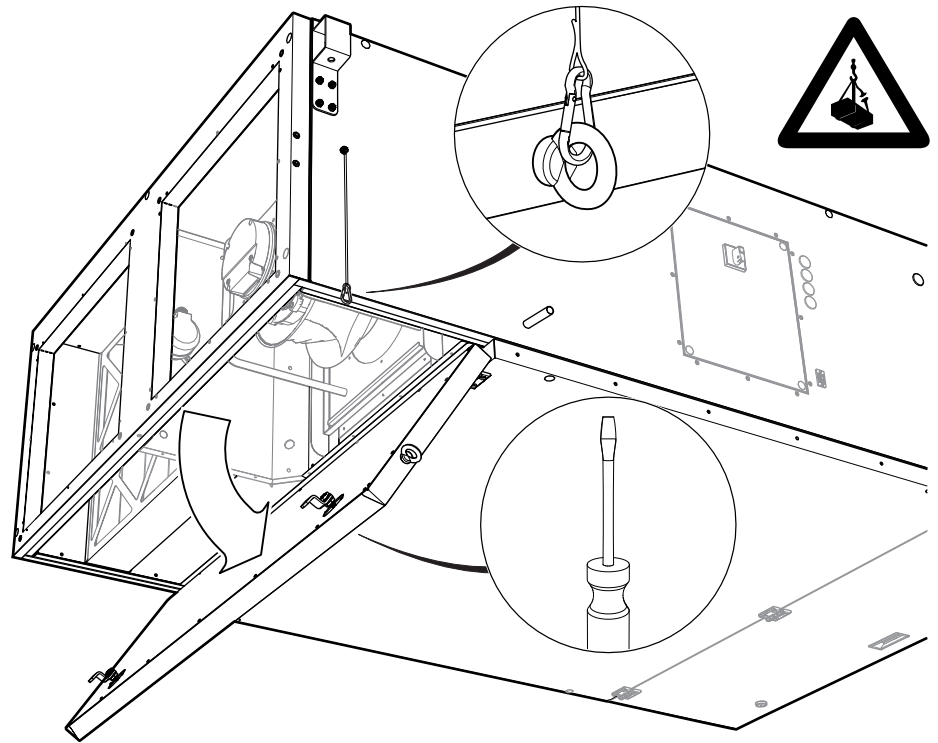

Filter Access

Fig. 18

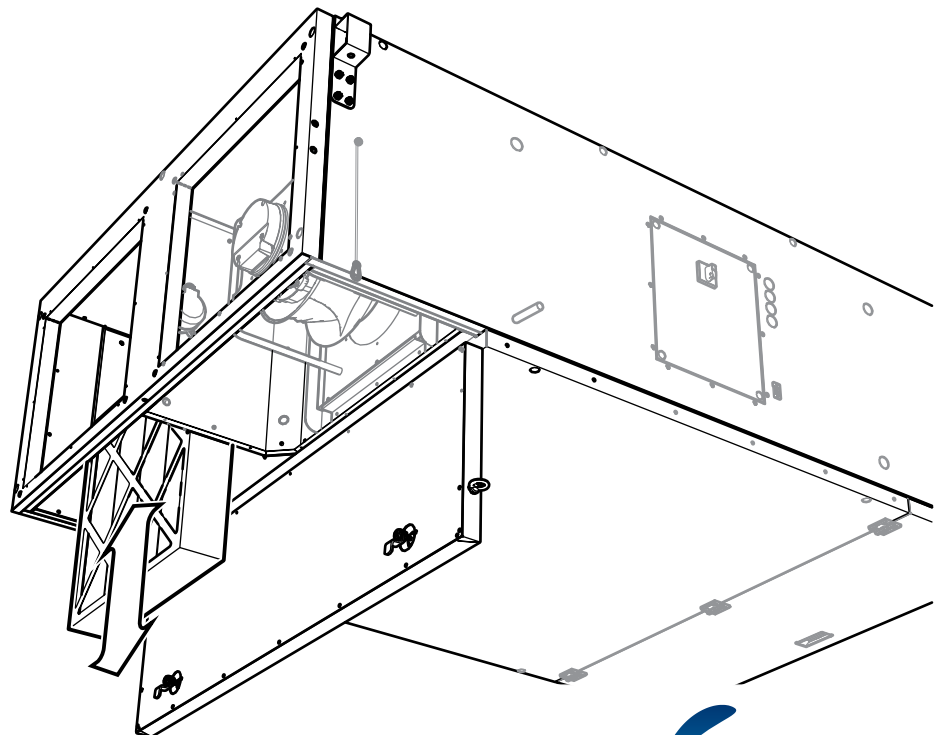

Maintenance
Six Monthly Checks

7

Continued

The fan impeller shall be cleaned at intervals of six months. Failure to perform regular cleaning may result in reduced fan performance or impeller imbalance. If the fan remains stationary for extended periods in a humid environment, it shall be operated for a minimum of two hours each month to remove any moisture that may have condensed within the motor.

Fan motors are maintenance-free, as they are fitted with ball bearings containing lifetime lubrication. When the grease service life of the bearings is exhausted, the bearings or the complete fan assembly shall be replaced. Under normal operating conditions, the typical bearing service life is approximately 30,000 to 40,000 operating hours.

Failure to keep dampers clean may result in improper operation. To prevent malfunction, the damper blades and frames shall be cleaned using a dry cleaning method.

The heat exchanger matrix shall be inspected for the presence of debris, dust, or dirt accumulation. If contamination is detected, all foreign material shall be removed. Cleaning shall be carried out with the heat exchanger module in situ. Light dust or loose debris may be removed by gentle brushing of the heat exchange surfaces, followed by vacuuming or flushing with warm water. Persistent contamination may require cleaning with a low-pressure washer using an approved detergent solution, provided that the solution temperature does not exceed 50 °C.

Care shall be taken to avoid damage to the heat exchanger when using any pressurised cleaning equipment.

Caution



Under NO circumstances should the heat exchanger be steam cleaned.

Important



Complete removal of the heat exchanger module is not normally required. If this condition occurs, contact VES customer support for further information.

Please ensure that the drain pan and drain connection are clear of debris so that any condensate produced can freely drain away. If a pump is installed, inspect the sensor and float for contamination and clean them if necessary using a 95/5% water/chlorine solution. Also, inspect all associated pipework and replace any damaged or blocked pipes. Replacement pipes can be obtained from VES if required.

If a comprehensive service is needed, it may be necessary to dismantle the unit's casework to access certain components. If it is necessary to remove the damper, follow these steps: unscrew the spindle that holds it in place on the blade, slide the spindle/actuator out from the damper, and then remove the damper side fixings.

Twelve Monthly Checks

ecovent® *midi* units are supplied unpainted as standard. If the version supplied includes a powdercoat paint finish check all painted items to ensure that they have not deteriorated, particularly where adverse environmental conditions prevail. Re-paint as necessary. Matching paint can be supplied upon request.

Maintenance
Spares & Repairs

7

Continued

When enquiring after or ordering spares contact VES Spares Department, quoting the sales order (SO) number and unit type as found on the unit nameplate.

Tel: 02380 461150

Spare Parts List

Fig. 19

Part Number	Part Description
ZL0201/A01/1184176/41/20	Fan Assembly (size 4)
ZL0401/A01/41/20	Fan Assembly (size 5)
GLB141.1E/41/50	Damper Actuator
EVC MDF400	Size 4 Filter G4
EVC MDF500	Size 5 Filter G4
EVC MPF400	Size 4 Filter F7 (Optional)
EVC MPF500	Size 5 Filter F7 (Optional)
PSGN1017	Filter Pressure Switch
FX002404	ø15.9mm Hole Domed Cover Cap
09-FA02-PLS00460A	Wire Safety Bond
PPPKT01	Condensate Pump Kit (includes pump, tubing and tube clips)

WEEE Directive



At the end of their useful life the packaging and product should be disposed of via a suitable recycling centre. Do not dispose of with normal household waste. Do not burn.

PLEASE ENSURE THAT THIS DOCUMENT IS PASSED ON TO THE END USER



 **ecovent[®] midi**
heat recovery

Counterflow Heat Recovery Units

Operation & Maintenance Manual

©VES Andover Ltd. 2026
VES is a trading name of VES Andover Ltd.
Registered in England No. 02303719.
Registered Office as above.



Eagle Close, Chandlers Ford Industrial Estate, Chandlers Ford, Eastleigh, Hampshire, SO53 4NF
Tel: +44 (0) 2380 46 11 50 email: info@ves.co.uk web: www.ves.co.uk